

REGA

Broadcast News

Volume No. 169, February 1981



CNN Delivers
Non-Stop News Via Satellite

Simply fantastic picture quality. Fantastically simple set-up. Get both with our renowned TK-47.

Press a button, and it sets up automatically. In seconds, instead of hours. File and recall six basic lighting situations, and get great picture quality—instantly—under any conditions.

All RCA cameras are built to extend your creativity, lighten your chores, and deliver the very best on-air product.

Our TK-86 is light, rugged and agile enough to go anywhere and start shooting right away.

Our TK-760 has enough heft for smooth studio work, yet is light enough for easy transport to the field as an EFP camera.

And with them all comes famous RCA TechAlert service to keep you on the air, come what may. Your RCA Representative can tell you more. RCA Broadcast Systems, Building 2-2, Camden, N.J. 08102.

SIMPLY FANTASTIC.



Can you really
afford less?



Page 6 News . . . Around the Clock; Around the World

From its Atlanta headquarters, Cable News Network delivers full-time news programming via satellite. Getting the system on-air involved a major investment in equipment, facilities and people. Planning, equipping and operating the system are discussed in this article.



Page 14 WBTW—TV Extends Coverage with Tall Tower and CP Operation

With its new 2,000' tower, circularly polarized antenna and 60 kW parallel G-line transmitter, TV-13, Florence, SC, has increased its coverage by a hefty 70%.



Page 20 NASA TV Systems Ready for Space Shuttle Coverage

Three NASA TV mobile vans with TK-76 and TK-760 cameras are in place at Kennedy Space Center to cover the Space Shuttle launch. The television equipment is fully utilized for other applications as well.



Page 23 Video Base Does It All From Hollywood—Florida

From a modest film operation to a major total service video tape facility . . . that's the Video Base growth story. The people, equipment and operating style are covered in this report.



Page 28 CBN's New 4-Studio TV Production Center

When Christian Broadcasting Network planned its new headquarters in Virginia Beach, a major television production center was integrated into the building design. This state-of-the-art technical facility is described here.

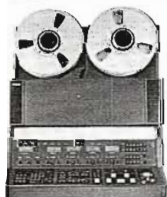

Page 35 TR-800 VTR: A Computer-Based Total System Design

Microprocessor technology was extensively applied in designing RCA's TR-800 one-inch Type C video tape recorder and its complement of system accessories. The distributed processing system, functions, controls, and major system components are described and diagrammed in this article.

View Finder

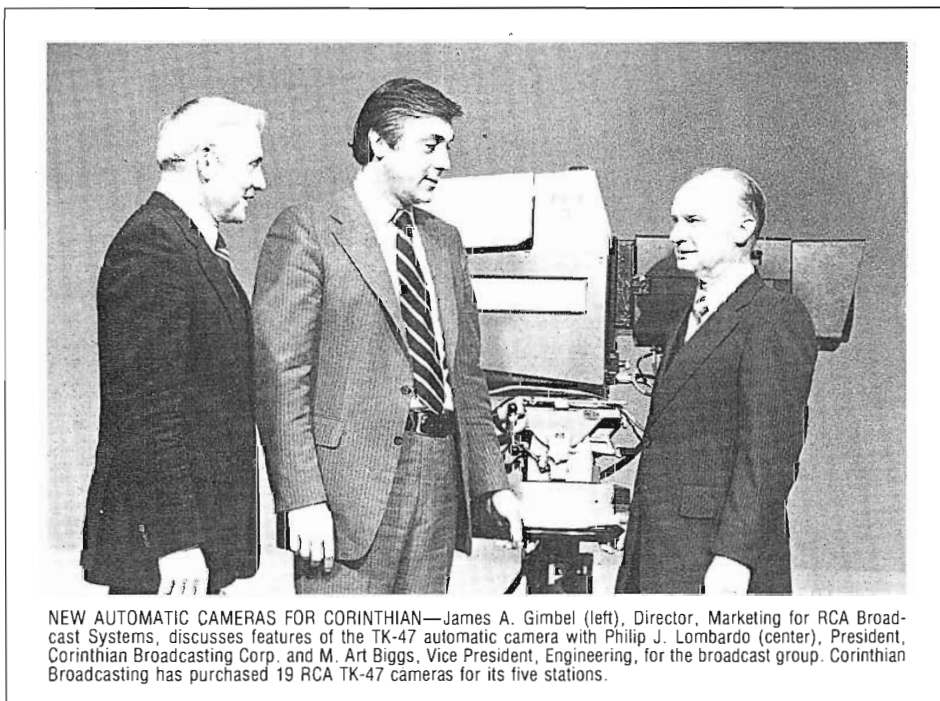

NEW AUTOMATIC CAMERAS FOR CORINTHIAN—James A. Gimbel (left), Director, Marketing for RCA Broadcast Systems, discusses features of the TK-47 automatic camera with Philip J. Lombardo (center), President, Corinthian Broadcasting Corp. and M. Art Biggs, Vice President, Engineering, for the broadcast group. Corinthian Broadcasting has purchased 19 RCA TK-47 cameras for its five stations.

Corinthian Broadcasting Orders 19 TK-47 Cameras For Group Stations

Corinthian Broadcasting Corp. is expanding the program production capabilities of its five group television stations with the purchase of 19 RCA TK-47 automatic color TV cameras.

The equipment on order, which also includes 60-kilowatt VHF TV transmitter, is valued at approximately \$3 million.

The TK-47 cameras will be installed in Corinthian stations KHOU-TV, Houston; KOTV, Tulsa; KXTV, Sacramento; WANE-TV, Fort Wayne; and WISH-TV, Indianapolis. In addition, KOTV will install a new RCA TTG-30/30L parallel transmitter.

M. Art Biggs, Vice President, Engineering, Corinthian Broadcasting Corp., said the time-saving efficiencies of the new automatic set-up cameras will enable each of the group's stations to increase its production and origination of local programs.

Storer Broadcasting Upgrades With \$3.5 Million RCA Buy

In a major upgrading and expansion of the technical facilities at its seven group TV stations, Storer Broadcasting Company has ordered RCA television studio and transmitting systems valued at \$3.5 million.

The equipment orders include 25 color TV cameras, one telecine system and four transmitters.

WTVG, Toledo, Ohio will install a TTG-30/30H, 60kW parallel transmitter. Two TK-47 automatic studio cameras and a TK-29 telecine system will be installed in the station's new studios.

WJKW-TV, Cleveland, also will upgrade its transmitting facilities with a TTG-30/30H parallel transmitter.

A total of 11 TK-47 cameras will be placed in service by three Storer stations: WJBK-TV, Detroit; KCST-TV, San Diego; and WSBK-TV, Boston.

Storer stations WAGA-TV, Atlanta, WITI-TV, Milwaukee, WJKW-TV and KCST already have expanded their electronic newsgathering capabilities with a total of 12 TK-76 portable color cameras.

New Transmitter For WCNY-TV, Syracuse

WCNY-TV, a non-commercial educational station serving the Syracuse, N.Y. area on Channel 24, will greatly increase its effective radiated power (ERP) with a new RCA transmitter and antenna system.

The equipment order includes a TTU-110, 110-kilowatt UHF transmitter and a TFU-25G pylon antenna.

Hugh Cleland, Chief Engineer for WCNY-

TV, said the station's new high-power transmitter and antenna will combine to produce more than two megawatts of effective radiated power. The new transmitting system is scheduled to go into operation in mid-1981.

Capitol Broadcasting Upgrades Transmitting Facilities

Capitol Broadcasting Company Inc., is upgrading the transmitting facilities of its television outlets in Jackson, Miss., and in Colorado Springs, Colo., with RCA transmitting systems valued at approximately \$1 million.

WJTV is operating on Channel 12 in Jackson, with an RCA TTG-30/30H, 60-kilowatt VHF transmitter. The new transmitting system consists of two 30-kilowatt units operating in a parallel configuration to produce 60-kilowatts of

visual power output.

KKTV, Channel 11 in Colorado Springs, is replacing its existing transmitter with an RCA TTG-17/17H, a parallel configuration transmitter producing 34-kilowatts of visual power output.

The RCA G-Line transmitters feature the latest in advanced solid-state design technology. Only two tubes are used in the transmitter, one visual and one aural, with all circuitry being solid-state up to the final power amplifier tube.

Video Post, Dallas— A New Full Service Teleproduction Center

Video Post, a new subsidiary of Soljay Productions in Dallas, Tex., is establishing a full-capability one-inch video tape post-production editing facility equipped with RCA TH-200 recorders.

The equipment order includes three TH-200 one-inch recorders as well as a CMX editing system and Grass Valley switching equipment.

Sol Benatar, President, said Video Post will be the first post-production facility in the Dallas area to offer full-service computerized time code editing capabilities for the SMPTE Type "C" one-inch format.

Video Post already has in operation a TH-50 portable one-inch recorder for on-location program production. "Video Post will be able to complete a production from shooting, through post to distribution," Mr. Benatar said, "all on one-inch without changing from the Type 'C' format."

He added that the company's location at Dallas' own Love Field airport is convenient for program distribution, as well as for out of town post-production clients.

Three Milwaukee TV Stations Move To New Transmitter Site

In conjunction with a move to a new transmitting site three Milwaukee, Wis., television stations are installing RCA TV transmitters and antennas valued at \$2.5 million.

The equipment includes two UHF television transmitters and a VHF unit, along with associated broadcast antennas and transmission line.

WVTV, Gaylord Broadcasting Company's Milwaukee outlet, along with WMVS and WMVT, Milwaukee's public TV stations, have moved to their joint transmitter location following construction of a new 5,600-square-foot transmitter building and 1,013-foot multiple-antenna tower.

The move, coupled with the installation of the new transmitting equipment, is designed to improve the picture quality, radiated signal and area coverage of the three outlets, according to station

officials.

Gaylord's WVTV, operating on Channel 18, will operate with an RCA TTU-55, 55-kilowatt UHF transmitter and a TFU-36JDAS custom-built pylon antenna. Channel 18's antenna is mounted on one side of a "T" bar arrangement at the top of the new tower.

WMVS and WMVT are operated by the Milwaukee Area Technical College. MMVS, Channel 10, has installed an RCA TT-35FH, 35-kilowatt VHF transmitter and a TW-12A Traveling Wave antenna, which shares the "T" bar atop the tower.

WMVT, serving Milwaukee on Channel 36, is operating with a new RCA TTU-60D, 60-kilowatt UHF transmitter and a TFU-28DAS pylon antenna. WMVT's antenna is side-mounted on the new tower structure just below the "T" bar.

Tel-Fax Facilities, Inc. Expands Mobile TV Operations

Tel-Fax Facilities, Inc. of Bath, Pa. has expanded its mobile teleproduction operations with the addition of RCA television cameras and video tape recorders, valued at approximately \$650,000.

The equipment includes four TK-47 automatic TV cameras, a TK-76C portable color camera, and a TH-200 one-inch Type C video tape recorder.

With the new equipment, Tel-Fax has expanded its mobile teleproduction operations which focus largely on sporting events, corporate communications and industrial training.

The new cameras and recorders joined two TH-200 machines with dynamic tracking capabilities and two TK-76 cameras already in operation at Tel-Fax. The company also uses three RCA TH-50 portable one-inch video tape recorders and a TKP-45 studio quality portable camera in its field productions.

WPHL-TV Expands Studio Production Facilities

WPHL-TV, Philadelphia, Pa., has modernized its program origination facilities and expanded its program production capabilities with RCA television studio equipment.

The new equipment for Channel 17 includes three TK-28B telecine islands and three TK-46 color cameras. A new TCR-100 video tape cartridge recorder joined an RCA unit already installed at the station.

The three new TK-46 cameras are being used in WPHL-TV's active commercial production center, according to Walt Bundy, Chief Engineer. The cameras operate in conjunction with three TR-600 quadruplex video tape recorders controlled by a CMX editing system, he said.

Malrite Broadcasting Orders Equipment For Four Group Stations

Malrite Broadcasting Company has ordered RCA television studio and transmitting equipment, valued at \$2.5 million, for two existing and two new group TV stations.

WCTI-TV, New Bern, N. C. will install an RCA Tetra Coil circularly polarized antenna atop a new 2,000-foot tower. The station also will expand its studio capabilities with TH-200 and TH-50 one-inch video tape equipment. WUHF-TV, Rochester, N. Y., also will install new one-inch video tape recording equipment.

Two RCA TFU-28 DAS pylon antennas also are included in the equipment order for use at two new Marlite stations under construction, in West Palm Beach, Fla., and in Jacksonville, Fla. The new stations also will install TH-200 and TH-50 recorders as well as TK-29 film originating systems.

KSTW, Seattle/Tacoma, Begins CP Operation

KSTW, Seattle/Tacoma, Wash., will begin circularly polarized TV broadcasts with a new model RCA Tetra Coil antenna.

The TCL-12A11 circularly polarized antenna for the Gaylord Broadcasting Company station will operate in conjunction with an RCA 75-kilowatt transmitter.

Designed and built at RCA Broadcast Systems' Gibbsboro, N.J. facility, the new Tetra Coil antenna is designed for tower-top mounting. It is made up of two layers of radiating elements, each consisting of four conductors. The antenna produces a power gain of approximately five in each polarization.

Four New Transmitters For NTV Network, Nebraska

The NTV Network, consisting of four television stations headquartered in Kearney, Neb., is upgrading the transmitting facilities of its group outlets with new RCA TV transmitters valued at more than \$1 million. The transmitters are part of a \$2.5 million technical improvement program underway at the stations. The equipment on order includes four TTG-30, 30-kilowatt VHF transmitters.

NTV Network, part of Amaturo Group, Inc., consists of the flagship station, KHGI-TV, Channel 13 in Kearney, and three Nebraska satellite stations: KWNB-TV, Channel 6, Hayes Center; KCNA-TV, Channel 8, Albion; and KSBNTV, Channel 4, Superior. The Group also owns and operates stations in St. Louis, Mo., Houston, Tex., and Ft. Lauderdale, Fla.

Louisiana Educational TV Network Enlarging Operations

The Louisiana Educational TV Authority has ordered RCA TV transmitting systems, valued at approximately \$2.7 million, to expand its viewing audience in the southern sections of the state.

The equipment order includes two TTU-60D, 60-kilowatt UHF transmitters and two custom-built pylon antennas.

The new stations in the state's educational TV network serve the Lafayette area in the south-central part of Louisiana, and the Lake Charles area in the southwest portion of the state.

Each transmitting system will produce approximately 1.5 million watts of effective radiated power, according to Coy Simmons, Director of Engineering for the Authority. The Lafayette station will operate on Channel 24, and the Lake Charles outlet on Channel 18.

"The new stations are the fourth and fifth in our planned statewide network aimed at providing educational TV coverage to all major population centers of the state," Mr. Simmons said.

The Authority's flagship station broadcasts on Channel 27 in Baton Rouge. Viewers in the northeastern part of Louisiana are served by Channel 13 in Monroe, and those in the northwest by Channel 24 in Shreveport.

Louisiana educational TV carries Public Broadcasting Service (PBS) and Southern Educational Communication Association (SECA) programs, supplementing them with locally-produced programming of special interest to its viewing audience.

New KCPQ, Tacoma, Goes On-Air With CP Transmission System

KCPQ, Channel 13, Tacoma-Seattle, a new commercial VHF television station serving the Puget Sound viewing area has begun maximum-power, circularly polarized TV broadcasts with RCA trans-

mitting systems.

In a complete modernization of its studio and transmitting facilities, the station has installed RCA Broadcast Systems equipment, valued at more than \$3 million.

The new transmitting system, including a TTG-30/30H, 60-kilowatt transmitter and a Type TBJ-12 circularly polarized panel antenna combine to produce the maximum 316 kilowatts ERP.

The transmitter site is located on top of Gold Mountain, approximately 12 miles southwest of metropolitan Seattle. With an antenna height of 2,395 feet above sea level, KCPQ's signal radiates from a point more than twice the height of any other television station in Western Washington, according to Bill Karpisek, KCPQ's Director of Engineering.

KCPQ-13's "maximum" broadcast facility identifies itself with an on-air signature of "Puget Sound Television." Viewer mail indicates that the station does indeed serve the entire Puget Sound area and beyond, according to Mr. Karpisek.

Response from viewers indicates that KCPQ has been received on rabbit ear antennas from as far south as Clatskanie, Oregon (about 30 miles north of Portland) and as far north as Vancouver, British Columbia.

The modernization of the station's studio facilities included the installation of two RCA TK-47 automatic cameras, two TCR-100 video tape cartridge recorders, and four TH-200 one-inch video recorders, as well as two complete telecine islands.

Two RCA Outside Broadcast Vehicles For Romanian TV

Romanian TV, which is responsible for the nation's radio and television broadcasting services, is enhancing its color TV broadcast capabilities with the addition of two RCA designed-and-built outside broadcast vehicles.

The new program production vehicles,

valued at approximately \$2.3 million, are equipped with a total of six RCA TK-47 automatic color cameras and two TK-760 studio/production cameras. The equipment will operate on the PAL B color TV standard.

The new broadcast vans are scheduled to be placed in operation early in 1981 and will be used throughout Romania for color program production.

CBC To Install Seven RCA TK-47 Cameras In Renovated Toronto Studios

The Canadian Broadcasting Corporation will equip two Toronto television studios with a total of seven RCA TK-47 automatic color TV cameras.

These two studios are being completely renovated. The new cameras will be used to broadcast the English CBC's national news programs, as well as for other news and public affairs telecasts.

Major ENG-Telecine Camera Purchase By Televisa, S. A., Mexico City

Televisa, S.A., headquartered in Mexico City, has enhanced its program production and origination capabilities with RCA television systems valued at approximately \$1.2 million.

The equipment includes nineteen TK-76 portable color cameras, as well as three telecine systems.

The TK-76 cameras are being used by Televisa to cover news and sports events, as well as in the production of documentaries, cultural programs and other special broadcasts.

Three TK-28B telecine islands are being installed in Televisa's master control center for on-air program origination.

Mexican TV Stations Order RCA Transmitter/Antenna Systems

In a major upgrading of the technical facilities of nine TV station in Mexico, Telesistema Mexicano, S.A., and Fomento de Television Nacional, S.A., have ordered RCA transmitting systems valued at more than \$2 million.

Included are five G-Line transmitters and four broadcast antennas.

Four stations in Mexico City, Channels



KEY TURNOVER—Mr. P. Varlam (right), Chief, Studio Operations for Romanian TV, and Mr. D. Laurescu (center), Engineer, OB Van Operations, accept the keys to two RCA designed-and-built outside broadcast vehicles from L. R. Dongelewicz, RCA Broadcast Systems sales manager for Eastern Europe. The new broadcast vans are equipped with a total of six RCA TK-47 automatic color cameras and two TK-76 studio/production cameras.

2, 4, 5 and 8 each are installing a new RCA TTG-30, 30-kilowatt transmitter, beginning this summer. In addition, Channel 2 in Tijuana is installing a TTG-17, 17-kilowatt transmitter.

Antennas in the equipment order include Superturnstile models for Channel 9, Reynosa, and Channel 5, Istmo de Tehuantepec, Oaxaca; a dipole antenna for Channel 9, Altzomoni; and a UHF dipole model for Channel 14, Mexicali.

The equipment also calls for comprehensive test equipment for strict quality control of video signals at each of the stations.

Six Color Cameras For CFCN-TV, Calgary

CFCN-TV, Calgary, Alberta, Canada, has greatly expanded its studio and on-location program production and origination capabilities with the addition of six RCA color TV cameras.

Three RCA TK-47 top-of-the-line automatic color cameras have been installed in CFCN-TV's studios and are used for local news origination and other program production assignments.

In addition, CFCN-TV has placed in service three RCA TK-76C portable electronic newsgathering cameras which are being used for on-site news reporting and documentary productions.

National Christian Network Opens TV Program Production Center

The National Christian Network, Inc., is establishing a television program production and distribution center in Cocoa, Fla. Equipped with RCA video tape and film systems, the new facility provides complete production capabilities for religious programmers, including studio and remote assignments and post-production editing. The production center, designed and installed by RCA, includes quadruplex, one-inch and 3/4-inch video tape equipment and editing systems, as well as film originating and audio

equipment.

In addition, National Christian Network will provide satellite distribution services for religious programmers, including those programs produced by the company and those provided by programmers.

An RCA-designed master control system will feed an uplink for satellite distribution of programs to cable systems throughout the country.

New VTR's And Editing System Added By Jimmy Swaggart Ass'n

The Jimmy Swaggart Evangelistic Association is expanding the teleproduction capabilities of its Baton Rouge, La., facilities with the addition of RCA broadcast equipment valued at approximately \$500,000.

The equipment includes five TH-200 one-inch video tape recorders, a TH-50 portable VTR, as well as an AE-600 time code editing system.

The company currently uses four RCA TKP-46 portable production cameras and two RCA quadruplex video tape recorders to produce the Jimmy Swaggart evangelistic program.

Three of the new TH-200 recorders will be installed in the company's editing suite along with the AE-600 editing system. The remaining equipment will be installed in their 45-foot tractor trailer mobile unit.

RCA Broadcast Systems Engineer Wins Company's Highest Technical Achievement Award

Laurence J. Thorpe, an engineer with RCA Broadcast Systems, and three engineers with RCA Laboratories in Princeton, N.J., have won 1980 David Sarnoff Awards for Outstanding Technical Achievement, the company's highest technical honor.

The awards, presented by RCA Chairman Edgar H. Griffiths, were in recognition of "the conception, development and

design of a microprocessor controlled automatic studio camera system."

The totally new-design TK-47 color television studio and field camera was introduced in 1978. The camera features microprocessor-controlled systems which automatically perform normally complicated and time-consuming camera set-up procedures.

Sharing in the team award with Mr. Thorpe were Robert A. Dishert, Robert E. Flory and Charles B. Oakley of the RCA Laboratories.

The David Sarnoff Awards were established by RCA in 1956 to commemorate the fiftieth anniversary in electronics of the late General David Sarnoff. The awards to individuals have been made annually since then to scientists and engineers within the Corporation.

Dr. Matti S. Siukola, RCA Broadcast Antenna Engineer, Dies

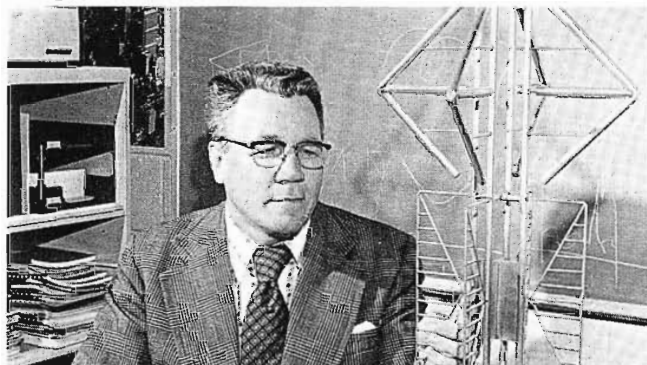

Dr. Matti S. Siukola, Unit Manager of Advanced Development for RCA Broadcast Systems' antenna engineering center in Gibbsboro, N.J. has died at the age of 58.

Dr. Siukola collapsed and died on September 19, 1980 at a meeting of the IEEE in Washington, D.C.

Dr. Siukola joined RCA in 1952 and made major contributions to the development of radio and television broadcast antennas. For the past seven years he was involved in the development of circularly polarized television broadcast antennas.

A native of Finland, Dr. Siukola was graduated from the Finland Institute of Technology with a bachelor's and a master's degree in Electrical Engineering. He received his Ph.D. in Communications from Oregon State University in 1952.

He was a Senior Member of the IEEE, and a Fellow of the Institute of Electrical Engineers in the United Kingdom. In 1974 Dr. Siukola received the David Sarnoff Award for Outstanding Technical Achievement, the company's highest technical honor, as a member of the team which designed the multiple TV antenna installation on Mt. Sutro in San Francisco.

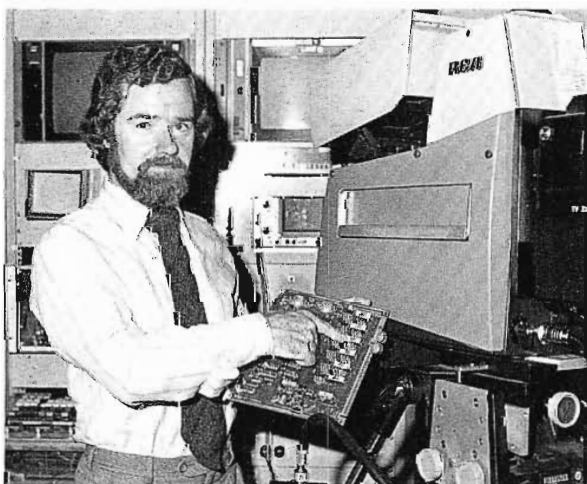

Laurence J. Thorpe



Anchor desk, with news room in background is the focal point of the CNN around-the-clock news flow.

CABLE NEWS NETWORK

An Around-The-Clock TV News Channel Designed To Succeed

“Once the faucet was turned on, it would never be shut off. That’s what we had to keep foremost in our thinking while planning Cable News Network. We had to be sure that everything was right—technically and operationally.”

Those words by Jim Kitchell, formerly Senior Vice President, Production and Operations for CNN, and now Corporate Vice President of its parent, Turner Broadcasting System, preface his enthusiastic description of what was involved in setting up the 24-hour-a-day, 168 hour-a-week news operation which

is Cable News Network. Kitchell, who came to CNN after a 29-year stint with NBC News, is proud of the accomplishments achieved by the new organization in less than a year.

Technically and operationally—from the sheer magnitude of the undertaking—Cable News Network is a remarkable success story. The technical facility at the Atlanta headquarters features numerous innovations that contribute to the smoothness and cost-conscious efficiency of the operation.

Veteran broadcaster Jim Kitchell now Vice President, Turner Broadcasting System, needed all of his expertise to get the CNN headquarters technical facility and bureau operations ready in a minimum time frame.

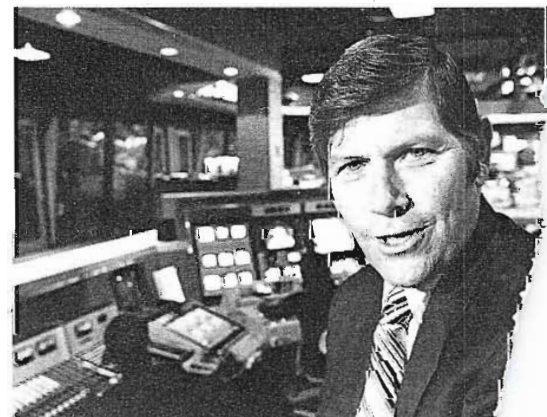

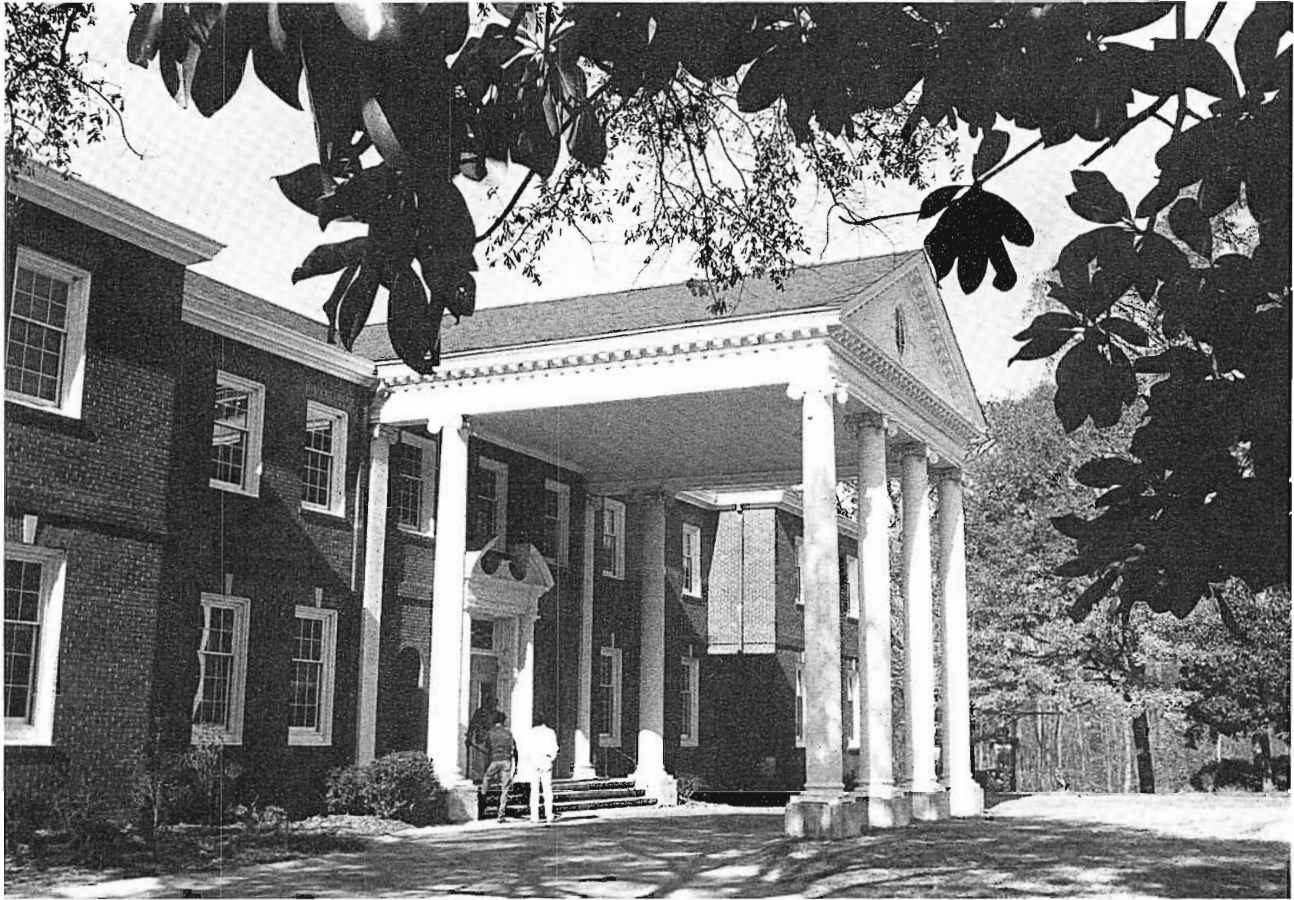

Attractive headquarters for Turner Broadcasting Company previously housed an Atlanta country club.

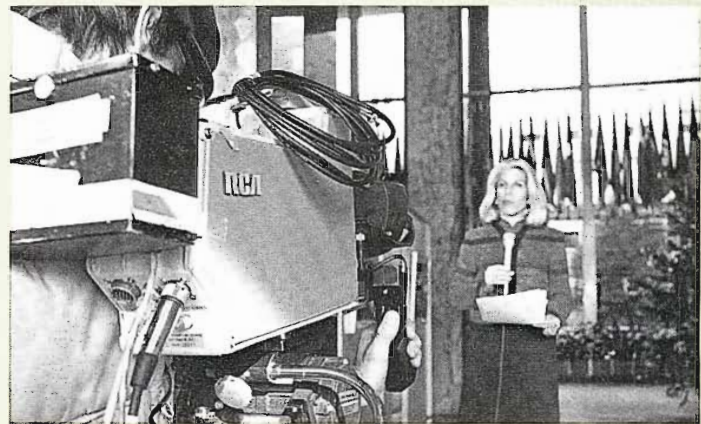

CNN's Washington bureau has its own studio and provides comprehensive coverage of political and national government news as well as special features.

Worldwide Newsgathering Facilities

For domestic news coverage, CNN operates seven bureaus, located in Washington, D. C.; New York City; Chicago; Dallas; Los Angeles; San Francisco, and Atlanta. The Washington and New York bureaus have complete studio facilities, including graphics systems, and carry assigned origination responsibilities in addition to on-going news reporting. These two bureaus are also connected to

the Atlanta headquarters by direct video telco lines. The New York bureau provides heavy business news coverage, while the Washington office features in-depth treatment of national political news. The other offices transmit by satellite, and all are equipped for live broadcasts. TK-76C portable cameras and BVU-110 recorders are used for ENG field operations at all locations. Overseas bureaus are located in London,

Rome and Tel Aviv, with another crew operating from Bangkok. For additional coverage, CNN has an exchange agreement with about 100 U. S. television stations and with CTV in Canada which provides access to its overseas bureaus, including a particularly useful one in Peking. Supplementary coverage for Europe is provided by the facilities of UPITN. Additional bureaus are planned for Detroit, Miami and Tokyo.

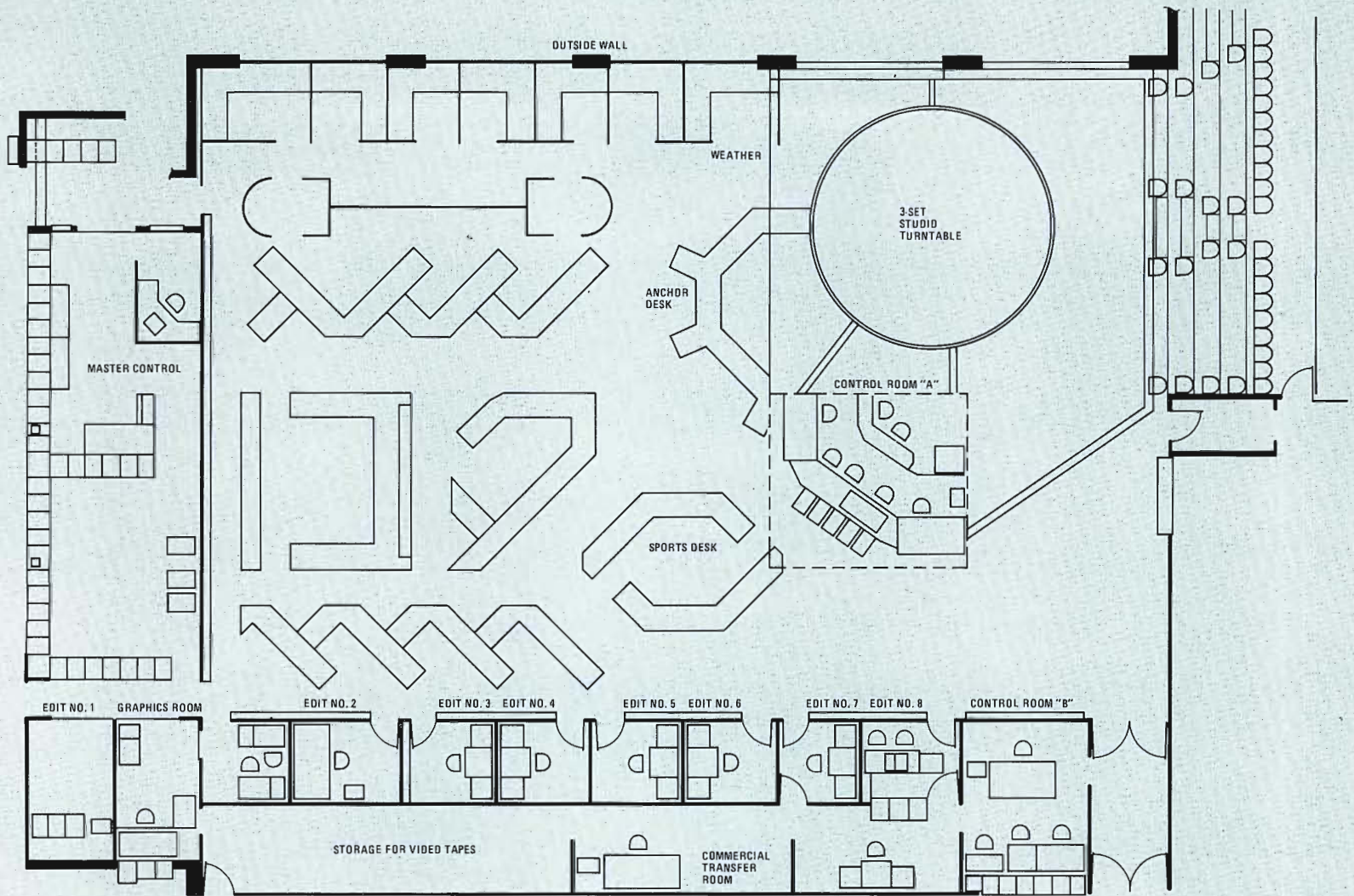

Basic Layout, Cable News Network
ATLANTA

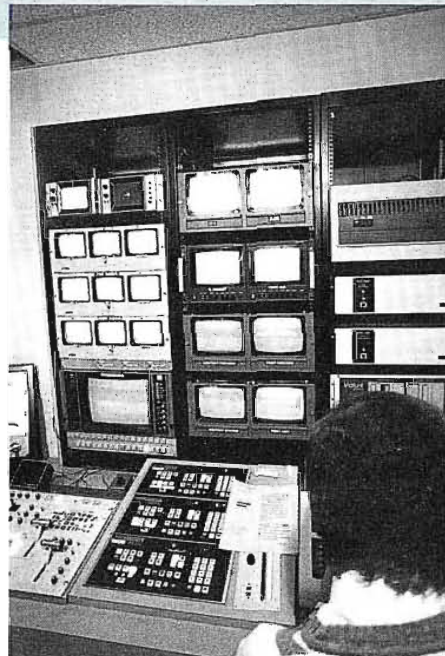

Glass-enclosed spaces along one wall of the CNN technical facility are used for major support functions: Production Control "B"; eight video tape editing rooms; a complete Graphics operation.

A Well-Planned Technical Center

The thorough planning that resulted in this TV production complex becomes readily apparent in a walk-through of the facility.

The action center for CNN is a large, open and extremely utilized area in a building that once housed an Atlanta country club.

The ground-level space is functionally arranged to serve the demanding operational and technical needs of its occupants.

At one end of the space is a raised seating area which faces a studio used for panel interview, and audience participation shows and for other program production. The studio "set" is actually mounted on a rotating turntable which carries three permanent sets.

To the left of the turntable is Production Control A, the main switching and control center for CNN. This space is also referred to as "the pit" because it is recessed below floor level.

Beyond and to the right of Production Control A is the main "anchor" desk and weather set. A separate Sports Desk is located at right angles to the left of the main "anchor" position.

Four RCA TK-47 automatic color cameras are used for news and program production. These are supplemented by four TK-76 portable cameras which are used by the Atlanta office for outside news coverage and for in-house production.

(The major camera purchase by Cable News Network totalled \$1.8 million including eight TK-47 cameras and 21 TK-76C portable cameras which are used by the domestic CNN bureaus.)

"Open" News Set

CNN operates with an "open" news set, with the normal newsroom activity going on in the area behind the anchor desk. This space is divided into clusters of functions. One cluster is the Assignment Desk; another is the Producer's Desk, and at the rear is a "Satellite and Circuits" desk which coordinates the incoming transmissions from satellites and telco lines.

On the outer perimeter of the room are Reporter's desks, which include as standard equipment the video display terminals and keyboards which play an important role in the computerized CNN news operation.

At the extreme rear of the room is a glassed-in space which houses the computer terminal equipment and Master Control.

Other Technical Facilities

Additional technical facilities are located in glassed-in spaces along one side of the main area (the other side is the windowed, outside wall of the building).

The first enclosed space is Production Control B. Located near the open Production Control A, it is used for production and as a back-up. (For added redundancy, a third video switcher in Master Control can also be used on-air.)

Adjoining Production Control B is a line of eight individual tape editing rooms, three for 1-inch and five for 3/4-inch tape. Behind the editing rooms are tape storage areas and VTR's that are used primarily for playback. One of the perimeter offices is "Graphics", a critical element in the CNN operation, since graphics are a part of virtually every news segment. Controls for the Adda Electronic Still Storage system; dual Vidifont character generators; a video switcher and a graphics camera are located in this active area. The ESS system provides 1/2 second access to 3,000 stored stills.

Programming Around The Clock

CNN programming is live for 20 1/2 hours a day, from 6 A.M. to 2:30 A.M. The

final live segment is a half-hour sports-cast beginning at 2 A.M., an important time slot, since CNN programs are transmitted to Alaska and Hawaii. From 2:30 until 6 A.M., prerecorded "Best of the Day" taped material is aired, although the news room is always "hot" for bringing in and transmitting a breaking story.

Scheduling desk keeps track of assignments and maintains status control of key program segments as they develop.

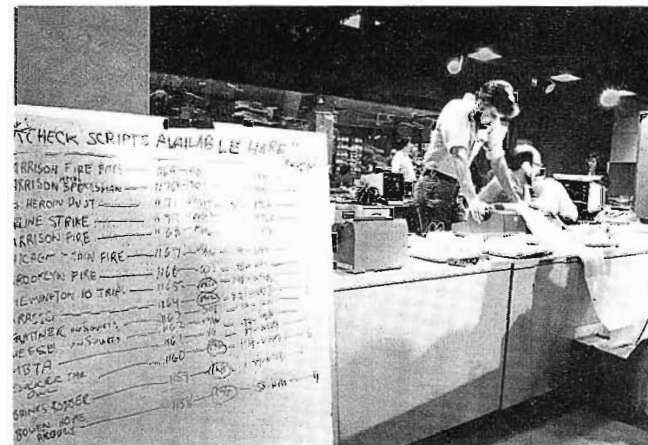

View from behind the anchor desk. TK-47 cameras are equipped with "Auto-Cue" prompters.





Jack Ormand, Chief Engineer for CNN: "The technical facility was designed to 'go any way'—to fit whatever operational requirement that might develop."

Excellent Camera Performance

Four TK-47 automatic cameras and two TK-76 portables are used for program production in Atlanta. Both types of cameras have been performing well, CNN's Chief Engineer Jack Ormand affirms. "The TK-47's produce top quality pictures and are very stable. The TK-76's in the field have lived up to their reputation for dependable performance under all types of operating conditions. And, when needed, service and technical support from RCA has been readily available and efficient."

Jim Kitchell also gives the cameras high performance ratings. "The TK-47 is a very fine camera, unquestionably the best studio camera that I have seen," he comments. "The TK-76 portables get a lot of use, and they, too, are performing well. It has been a durable, reliable camera for us.

"Recognizing that the cameras were bought as a composite package, but would be dispersed for use in various field locations, the ability of having the RCA service organization available on-call on a national basis was a major factor in making the purchase from RCA," he concludes.



Set-up and remote controls for TK-47 cameras are located in Master Control.

Daily "Auto-Check" Confirms TK-47 Stability

The TK-47 cameras at Atlanta are seldom turned off, Mr. Ormand adds, and maintenance has not been a problem, although it is handled on a "catch-as-can" basis between program blocks, or while New York and Washington bureau programs are being aired. As a matter of routine, each of the TK-47's is given an "Auto-Check" once a day from Master Control, where the Remote Control Units and the Set-Up Terminal for the cameras are located side-by-side near the MC switcher.

Planning The System

Much of the operational and technical flexibility of the CNN facility is a projection of Jim Kitchell's saturation experience in television—as a director, producer, and network news department executive. An early advocate of electronic journalism, one of his assignments was to start up the ENG operation at NBC.

From the start, Cable News Network was planned as a full-time, around-the-clock news and information operation, Mr. Kitchell affirms.

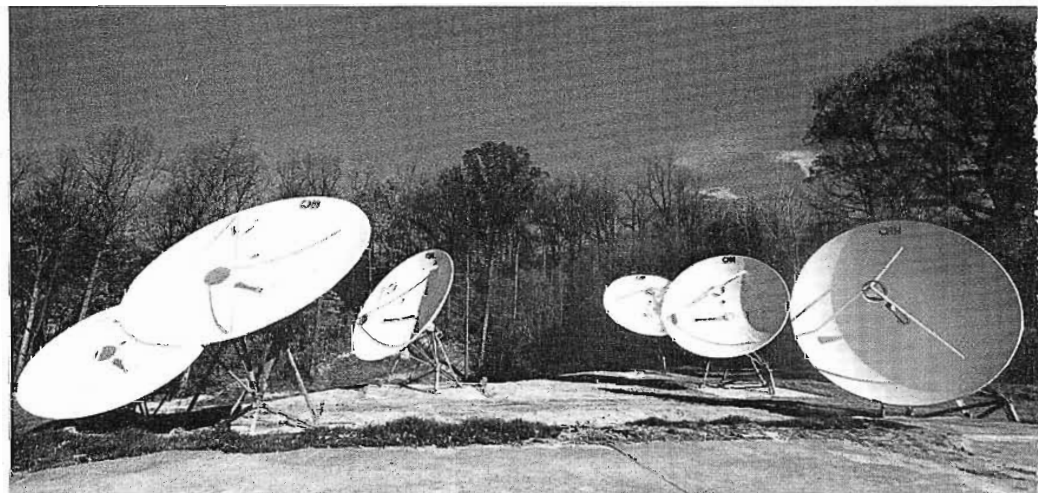

The satellite ground installation was a turnkey project handled by Scientific Atlanta. The system includes six dishes—five 7-meter and one 11-meter. There are 20 receivers—ten of which are switchable to any antenna and frequency. Some receivers are dedicated to specific satellites—Satcom I and II; Westar I, II, and III. (The 11-meter dish is dedicated to Westar III.)

All feeds come in to CNN headquarters in Atlanta for broadcast. Outgoing broadcasts are microwaved to Douglasville, Georgia for uplink to Satcom I. Controls for the satellite receivers and transponders are centered in Master Control, as are the telco circuits from Washington and New York.

"Satellites and Circuits" desk (right) is located in newsroom just outside Master Control.

In Master Control, a bank of monitors keeps track of incoming satellite and telephone circuit signals and maintaining quality control.

“Obviously to operate on that kind of a schedule you have to have a lot of flexibility in the system, and a certain amount of redundancy,” he elaborates.

“We knew that in the technical area we had to put in equipment that was durable and reliable—knowing that it was going to get the kind of wear and tear that has never been given to such equipment before.

“Timing was also critical. We did amazingly well, when you consider that we put the first rack in place in the Master Control Room the first week in February, and started rehearsals the first week in May. And it was all done with a small technical crew handling the installation.”

One person well acquainted with the intricacies of the technical system and the short time frame for its planning and installation is Chief Engineer Jack Ormand, who moved over to the new CNN organization from WTBS-TV, the flagship station for Turner Broadcasting Company, where he was Assistant Chief under Director of Engineering Gene Wright.

“The technical facility was designed to ‘go any way’—to fit whatever operational requirement that might develop,” Mr. Ormand says. He and his energetic crew of six worked long, hard hours putting in the system, and rearranging it “on-the-fly” to accommodate changing requirements.

Planning for the new facility started in September 1979, with equipment purchased before the end of the year. By January, the various equipment components began arriving and an installation schedule was set up. Computer flooring is used for the newsroom and technical

areas, which made it easier to make necessary layout and technical re-arrangements.

Production Control A— The “Open” Control Room

With the preponderance of live programming, Production Control is a critical function. Added demands are put on the “pit” crew by the extensive use of inserts and graphics; by the numerous video sources involved, and by the frequent use of outside pickups from satellites and direct circuits. Maintaining a smooth on-air operation with the numerous transitions involved in the combined live and pre-recorded news presentation requires concentration and coordination. At CNN, Production Control is a five-

person operation, including Producer, Director, TD, Audio, and Graphics. The audio board is located in the Production Control space, along with a Grass Valley 1600-7K switcher, machine controls and Vidifont graphics system. The “crawl” operator sits just outside the control area, feeding copy to the camera prompter monitors.

Since the news copy is generated on the news room computerized system, future plans call for transmitting copy directly to the camera prompters without the transfer to paper and the crawl operation. Aside from the added efficiency, Mr. Kitchell estimates a saving of 500 pounds of paper a day if the computer system were utilized to eliminate paper throughout the news operation.



Action hub for the CNN operation is Production Control “A”, a recessed, un-enclosed facility adjacent to the main anchor desk.



An unusual feature of Production Control is that it is completely open on all sides, an arrangement that permits it to be used on-air as a functional part of the news presentation. “We had the idea that we would like to have an open control room—which had not been done before,” Kitchell remarks. “There were some concerns about whether it would work, or if the noise level would be too high. Consequently, we put the control room inside four columns so we could close it off if necessary. We have not had to. It works extremely well, and the ambient noise level is such that it is a natural background and not distracting to the on-air operation. We use the control room as a part of the overall operation.”



Master Control includes graphics, switching, camera control, satellite receiver controls and extensive monitoring facilities.

essential for CNN, since numerous internal and external video sources are involved, with access required in many locations. Three routing systems are used in the technical facility.

Routing System 1 is a 32 x 32 system for incoming signals. It handles routing for 20 satellite channels; four off-air tuners (for the network stations and WTBS) and one telco line, plus a spare.

Routing System 2, the House Routing System, is a 32 x 48 switcher which makes any signal available anywhere in the building. Its inputs include:

- 20+ for ¾-inch tape machines
- 13 for 1-inch VTR's
- 1 for video "cart" machine
- 1 for quad VTR
- 1 for Production Control A
- 1 for Production Control B

Routing System 3, a 16 x 8 output switcher, provides extra flexibility in the system.

A Minimum of Dedicated Equipment

The versatility of the routing systems lets the CNN technical facility function with a minimum of dedicated equipment. "If you start dedicating too much, you're going to bog yourself down with personnel and facilities, so you can't use either with maximum flexibility," Kitchell points out. "And if you have a 'crash' of one piece of equipment, then a whole facility is out of operation."

Video Switching Systems

A complement of four video switchers is used in the CNN headquarters technical center. Production Control A is equipped with a GV-1600-7K switcher and Production Control B has a 1600-7F system, both with E-Mem facility, with seven memories for each effects bank. A 1600-1L is installed in the Graphics Room, while Master Control has a 1600-4S switcher which is used for airing commercial blocks during the day, and is used as the on-air switcher for the early morning shift.

Three Routing Systems

Flexibility in moving around the plant is

"For example, one of the things we did with ¾-inch tape was to go to a central playback area, so that you're not tying up an edit room and its facilities to playback, which requires only one machine. Here, as soon as a piece of tape is finished editing, it goes into the playback area, and is available for use by different segments of the programming operation.

"Although everything funnels through Atlanta, we try to do as much of the editing on location as possible, because it is better to have the people who developed the story follow it through. Also, if we get a lot of unedited material dumped in here, it bogs down our editing facilities, and slows up the operation because we are now a step removed from the story source."

Three-Set Studio

The turntable studio is another innovation that is ideally suited to CNN's operating style which emphasizes production efficiency and economy. "We wanted to have the capability of changing sets, but needed to be able to change them quickly," Mr. Kitchell explains. "We had very limited storage space and an equally limited time for striking a set. The solution was putting three sets on a turntable, so you can turn them into place and use them as permanent sets. It has worked out quite well. We're effectively doing two shows at the same time. While we're on-

Compact studio features three permanent sets on a revolving turntable, and is well utilized for program production. An audience seating area is provided.



air with the anchor desk, we're also taping a program on one of the turntable sets. With the permanent sets, we can pre-set lighting and also camera positions, which makes for efficiency in getting the job done quickly and without a lot of lost motion."

Computerized News Room

Since the national political conventions and election, the "computerized news operation" has become a familiar trade term. It is a logical extension of today's technology, and, as might be expected, is an integral part of the CNN operation. The completely computerized newsroom in Atlanta includes 47 video terminals, and there are ten terminals in the Washington bureau, three in New York, and one in each of the other domestic bureaus.

"The computer has become vital to our full-time news operation," Kitchell avers. "Our system was developed by Robert Barnes, Director of Data Resources for CNN, and it is state-of-the-art all the way. The system gives us the capability of keeping all stories on file, identified and ready for instant recall. So when a story changes, you can update without re-writing—just use the video terminal to make the copy change."

According to Barnes, for each story the computer will list on a video display its wire service slug line; the anchor to whom it's assigned; the writer who handled it; whether it needs Vidifont or graphics; if there's videotape to accompany it; its length; whether the story has a copy editor's approval; if it's ready for air, and how long it will take the assigned anchor to read the piece. Barnes even has a small business computer programmed for, among other tasks, cost analyses of CNN coverage on a per-story basis.*

Video Journalists

CNN began operations with a staff of experienced broadcasting professionals—and with a fresh concept in staff development. The pro's are still on board, including such well-known and diversified camera talent as Daniel Shorr, Bernard Shaw, Barry Goldwater, Phyllis Shaftly, Don Farmer, Chris Curle and Sandi Freeman.

The operational staff developed by Jim Kitchell is based on the philosophy that "everybody can do everything".

"We wanted to avoid the pre-conceived notions about people being locked to one job or function," he explains. "Consequently, I developed what we call 'video journalists'. Basically what we did was to hire a group of young, fairly recent Journalism/Radio-Television college gradu-



In CNN's computerized news room, video display terminals are standard desk equipment for all phases of the operation.



ates who had been exposed to television journalism at their schools or who had summer job experience. We brought them in early in May when we started our pre-operational rehearsals. The freedom of being able to tackle everything is a great challenge to them. They work hard, study, and pick up job knowledge fast. The enthusiasm of these young people is tremendous—one of the greatest things going."

The CNN Video Journalists perform a variety of assignments—camera operator; floor director; video switching; graphics; scheduling; writing; editing.

Acclaim . . . Acceptance . . . Growth

The investment by Cable News Network, in equipment, facilities and talent has been and continues to be enormous. The CNN concept has been well received, and its execution has been critically acclaimed. The quality of news presentation and production compares favorably to that of the major networks.

Acceptance by cable system subscribers has been excellent—a significant consideration for those responsible for growing the CNN operation into a profit center.

Starting from a base of two million subscribers when the all-news network began broadcasting on June 1, the number of subscribers had doubled by January 1 to four million. And, with television being used increasingly by adults as their major source for news, CCN is anticipating an accelerating growth—in subscribers; in advertisers, and in increased services. □

*Broadcasting May 5, 1980

FLORENCE S. C.

WBTW-TV

Goes To CP Operation With 2000' Tower and New Parallel G-Line Transmitter

Over 100 feet tall, the TCL-16A Tetracoil CP antenna looks small as it rides to its lofty perch atop WBTW's 2,000 foot tower (left).

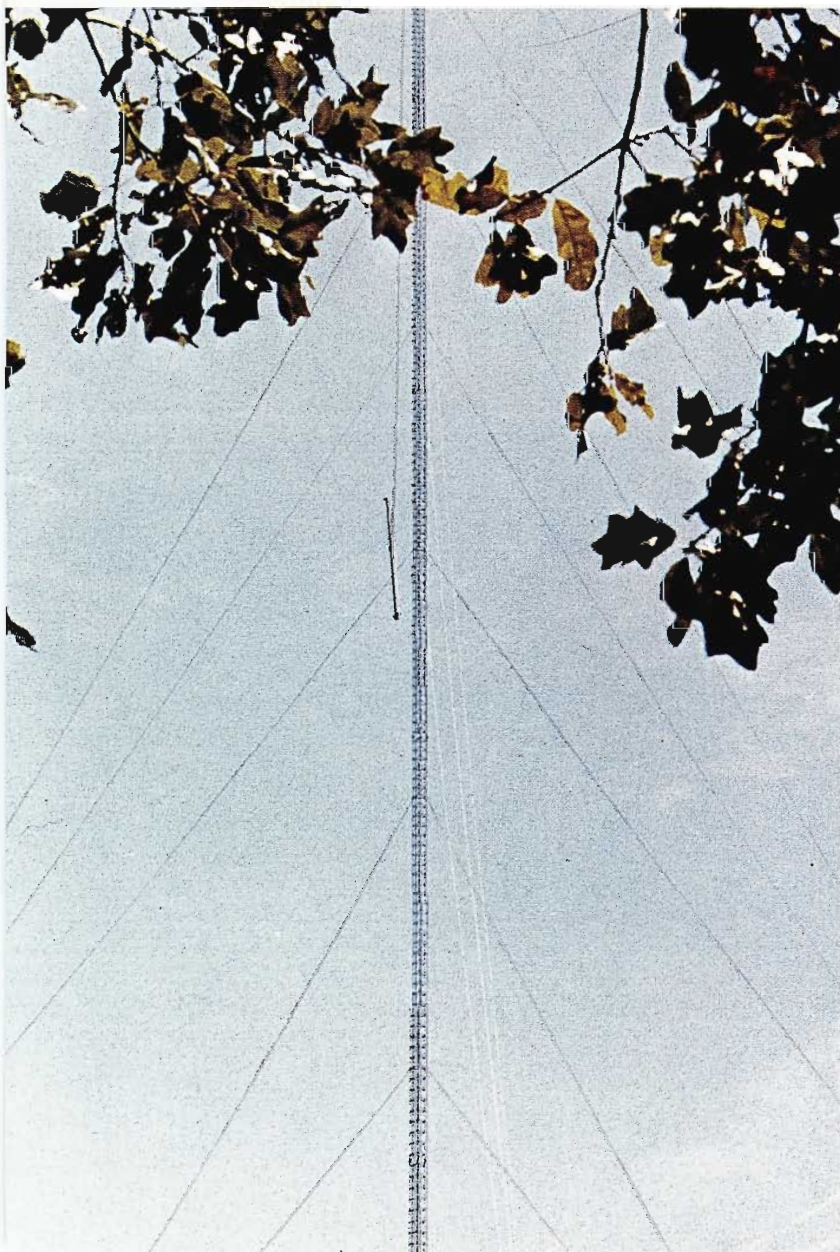

Trio of hardy riggers rest atop the TCL-16A Antenna as it leaves the ground.



WBTW-TV, Florence, S. C., started planning their new transmitting facility in 1969. Eleven years later, in September, 1980, the new transmitting system was in place and on-air.

For Bernie Moore, Vice President, Engineering, for TV-13, the results already achieved with the new system have made it easy to forget the long wait and the delays along the way.

“With the new tall tower, circularly polarized antenna and new transmitter, our coverage area has increased by 70%. We’re getting a strong signal throughout, and are putting an “A” grade signal into some areas which we barely reached with a “B”, he adds.

New Tower/Transmitter Site

The transmitting location was moved from the station’s studio in Florence to Dillon, S. C., some 24 miles to the Northeast. The change in tower location and height contributed to the extended coverage, but Mr. Moore also credits the circularly polarized antenna with greatly extended and improved signal reception.

“Our consultant will be making a field contour study later, but our own prelim-

inary checks and the topography would indicate that we will meet the projected coverage, which will improve our ADI.”

Since Florence is Market #162, extended coverage was obviously a significant factor in planning the new transmitting system. Some consideration was given to using translators for added coverage, but Mr. Moore believed it made more sense to go to the 2,000 foot tower, especially since the site selected for the tower was only eight miles from the North Carolina border. The flat terrain in the area permits taking advantage of the tall tower.

“We’re now getting CBS programming into the coastal areas from Wilmington, N. C. to Myrtle Beach and south to Georgetown, S. C., which we never reached before,” Mr. Moore says.

“The added coastal coverage is important, since the population in the Myrtle Beach area alone reaches 350-400,000 during the tourist season. With circularly polarized transmission, the people there can now pick up our signal on rabbit ears, and without critical tuning.”

- The circularly polarized antenna, a Tetracoil TCL-16A, is the first production model.
- The 100 kW notch diplexer is the first of its type.

Did installing a system with so many “firsts” bother Mr. Moore? Not at all, he says—and the performance of the system has more than justified his confidence.

CP Has Eliminated Many Problems

“The new transmitting system has more than met the goals we set for it,” Mr. Moore states. “Viewer reaction has been overwhelmingly favorable, even from those located 60 to 90 miles from the transmitter. In some areas where our signal power never got through, people are getting an absolutely perfect picture on rabbit ears. Circularly polarized transmission has eliminated many problems.

“I was prepared for some complaints about the change,” Mr. Moore continues, “especially from people who were removed 180 degrees from the previous antenna orientation. It hasn’t happened.

“The first call that came in on the morning that we went on-air with the new system was from a man who lives near Wilmington, some 80 miles away from the transmitter. He had a rotary antenna directed toward Durham, N. C., off ninety degrees, and was still getting a strong signal from TV-13!”

Long Planning; Quick Execution

Planning for a new transmitting plant and tower location began in 1969. After numerous studies and plans, a CP was issued at the end of 1978. This plan included the 2,000 foot tower, circularly polarized antenna and transmitter to be located on a working farm near Dillon. During 1979, suppliers were selected for the transmitter, antenna and tower, and construction began on the transmitter building.

Mr. Moore’s timetable called for having the transmitter building roofed in by February 1979 and the tower completed in June, to allow sufficient time for installing the antenna and transmitter. The air date for the new system was scheduled for early September, in time for the CBS football games and Fall season programming. There were minor hitches along the way, but with good planning and “work-arounds”, the schedule was met.

“There really wasn’t much doubt about the transmission system,” Mr. Moore notes. “From the start, the 60 kW TTG-Series transmitter and the Tetracoil antenna with its gain of 8 per polarization seemed ideally suited to our needs.”

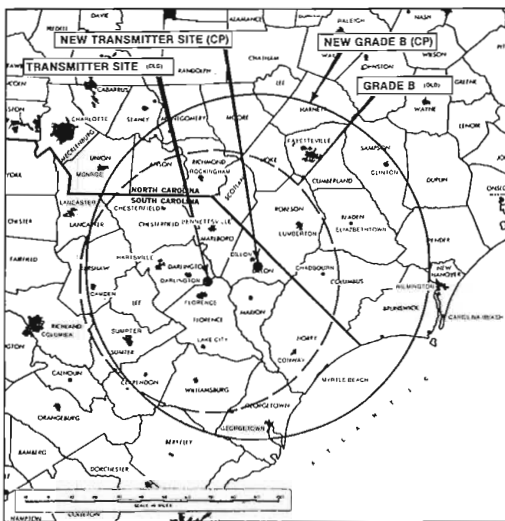

Coverage map shows TV-13’s extended coverage area with new tower and transmitting system.



Bernie Moore, Vice President, Engineering at power supply cabinet of TTG-30/30H Transmitter. The key interlock system of TTG Series transmitters is an important safety feature for unattended operations such as that at WBTW-TV.

A Pioneer System of “Firsts”

The transmitting plant and tower have produced a number of “firsts” for TV-13.

- The 2,000 foot tower is the tallest in South Carolina.
- The new transmitter, a 60 kW Type TTG-30/30H is the first parallel “G-Line” system installed.

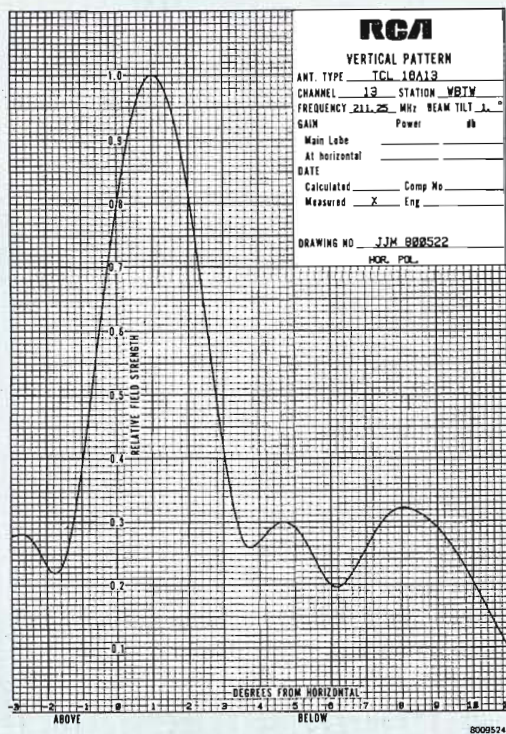
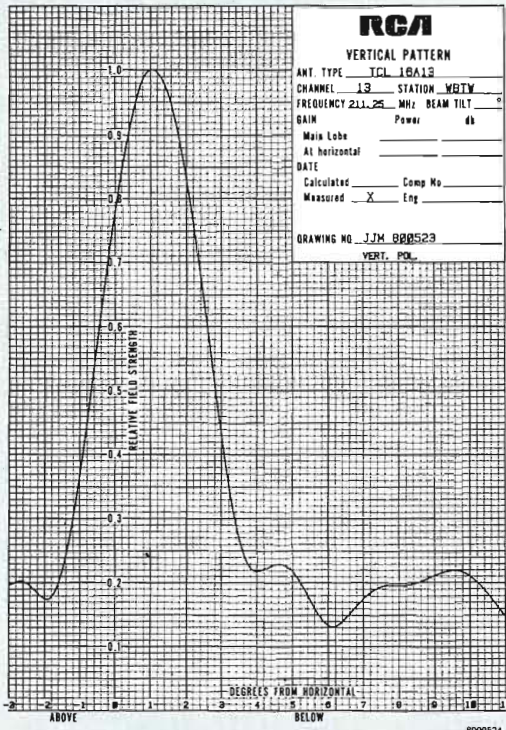

Measured Vertical and Horizontal Patterns for WBTW's TCL-16A circularly polarized antenna.

Top view from rear of TTG-30/30H Transmitter shows system interfaces: wiring interconnects; aural and visual outputs; air inlets and outlets.

Tetracoil CP Antenna: Less Windloading; Fewer Feedlines

In planning the TV-13 antenna system, Mr. Moore closely followed the progress of earlier circularly polarized TV operations, particularly those installed or being built for use in nearby North Carolina.

Commenting on his selection of the Tetracoil antenna, Mr. Moore notes, "Looking at it, the design is very simple. You have less windloading and fewer feedlines to give trouble as they age. There is very little on the antenna to get damaged. Also, the antenna is essentially at ground potential, which should be very good for lightning protection.

"As for performance, the circularity of our TCL-16 is better than 1/4 dB—about as pretty a pattern as I've ever seen. The overall results have been very good. Even with more than 1900 feet of transmission line, I am maintaining a VSWR of 1:04.

"The beam tilt for this antenna is 0.9 degrees, which puts the signal on the ground about 57 miles out. We didn't specify null fill, but the close-in picture quality is excellent."

60 kW Parallel Transmitter: "Just About Transparent"

The TTG-30/30H Transmitter at WBTW-TV went on-air September 10, 1980, without fanfare, ceremony or pre-event promotion. "I've been on-air for five weeks now and haven't made any adjustments to the transmitter—no tuning, broadbanding or anything. The stability and reliability have been excellent, and the transmitter is just about transparent. I come directly from the STL microwave to the transmitter without correction.

"This 60 kW system is just what we were looking for," Mr. Moore adds. "We are running it at 54 kW in parallel,

27 kW per side, with ample headroom for higher power output levels."

The TV-13 transmitting plant was planned from the start as an unattended operation, and it has been that from the first on-air turn-on.

"In operating in a small market, you

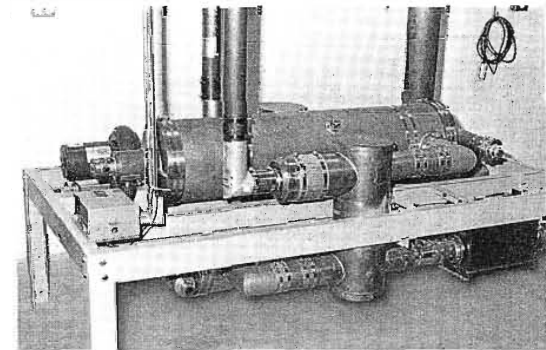

100 kW Notch Diplexer at TV-13 is the first installation of this type. The unit provides for the combining of aural and visual transmitting outputs into a common transmission line. It allows lowest VSWR, best response at 4.18 MHz, and operation at 20% aural power.

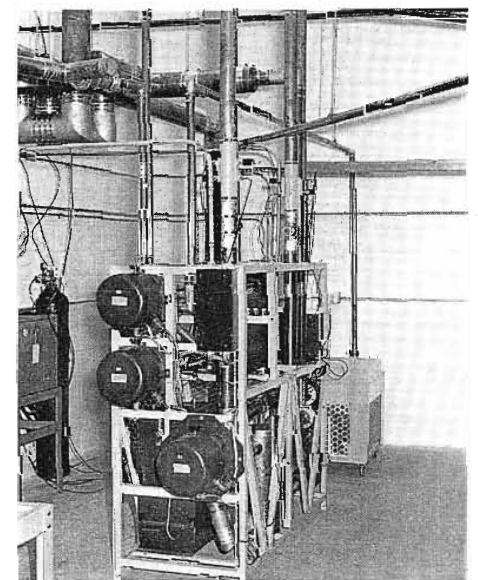

Optimized RF output switching unit—"OptoSwitcher"—provides for motorized switching of aural and visual transmitter outputs. Switches are packaged to allow for complete accessibility.

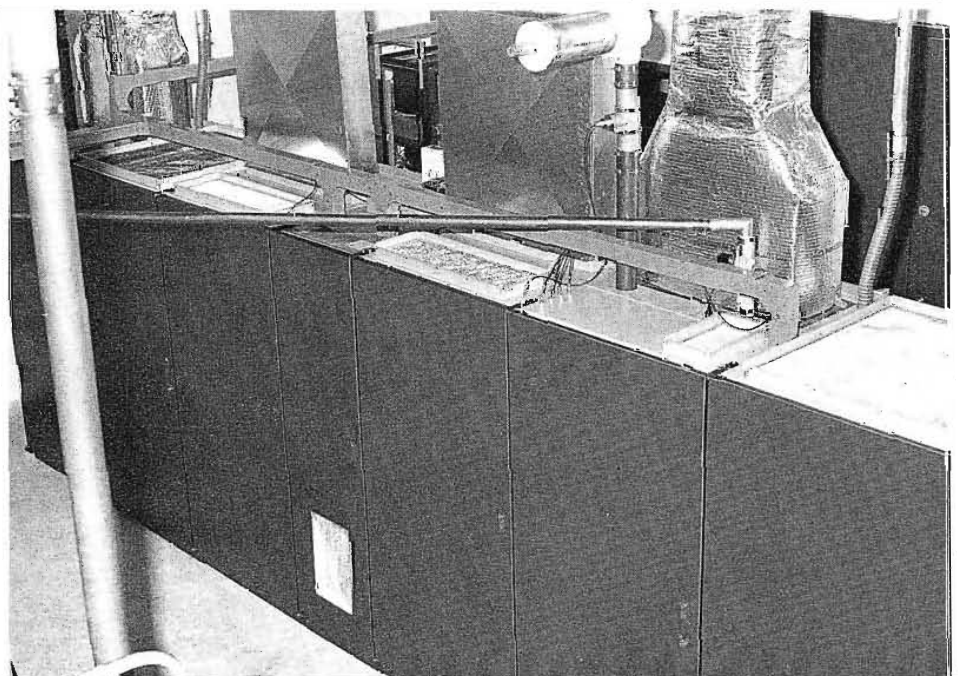

really need automatic equipment," Mr. Moore affirms. "The new G-Series transmitters are ideal because of their many automatic features and protective circuits. Our TTG-30/30H transmitter has so many protective features that I don't think it could hurt itself, regardless of what happened.

Transmitter Pre-Wired for Easy Installation

"I like the way the transmitter came in. It was all pre-wired, with very little hook-up required on site. The power supplies roll in, with only two cables to connect. Everything went together very simply, just using hand tools. I put it together myself, with just one other man here part of the time."

Four weeks after TV-13's TTG Transmitter was unloaded, it was tested on-air. During that time, the transmitter was installed, and electrical work, coax and inside transmission line hook-ups were completed. All of the rails and hangers for the transmission line had been previously mounted, which saved considerable installation time.

"Before unloading the transmitter, we had marked off with masking tape the exact floor locations of the various pieces of equipment. We moved the equipment in, set it down one time, and never had to move any of it.

"Ten days after the first test of the transmitter, we put it on-air for good. Since then, I have not had to make any special trips to the transmitter site."

Remote Operation From The First Turn-On

An indication of Mr. Moore's confidence in the new system: it was turned on from the studio, using the remote control

system on the first day of CP operation.

"I like the idea of the system operating without anyone here, and I am convinced that the transmitter runs better without people messing with it," he says.

The entire RF system was optimized by RCA Tech Alert and Service Company technicians, from transmitter to antenna, including the combining lines. The system includes an "OptoSwitcher", which Mr. Moore regards as a wise investment. "It made it much easier for putting in the coax," he says. All of the inside coax was installed in just five days. The 6-inch inside transmission line was cut, fitted and connected during that time.

"One more nice thing about this transmitter is that just about everything you need to know shows up on the LED status displays. Especially during checkout, if something wasn't right, you could look at the LED's and see exactly where the problem was. Another thing that I think is a real plus is using the same crystal to synthesize both the aural and visual carrier. You don't get variations in aural and visual when the same crystal is used."

"Taps" For The Veteran TT-50AH . . . After 201,000 Hours

After putting the new transmitting system on-air, TV-13 kept the old TT-50AH transmitter "hot" for about a week, then shut it down for good. This 50 kW workhorse had been on the job since 1954 when the station started broadcasting. During that time it logged more than 201,000 hours and has done "a hell of a job" according to Bernie Moore—who should know, since he was there for the initial installation and has been well acquainted with it during the ensuing 26 years.

More Radiated Power With Less Power Consumption

"Based on power consumption that I'm measuring for the new transmitter and compared to the TT-50AH, I'm running this 60 kW transmitter with a bit less power than the old one. My input power is just about the same. In planning, I calculated that the total power would come to 150 kW, with a power factor of about 96 to 97%. When this was checked out by the power company after going on-air, it was measured at 151½ kW—very close to predicted usage.

"When checked last spring, the old transmitter was running about 180-186 amps per leg—which comes out to just about 150 kW. In addition, I had 7½ horsepower blowers and other motors that took more power. Cost-wise, it looks like the new transmitting system will use about the same power as the old one, but the difference is that now, with CP operation, my transmitter output is 54 kW peak power, while with the TT-50AH, peak transmitter output power was 38 kW.

"In effect, I am operating two transmitters and getting much better coverage for the same power cost. In addition, tube costs are substantially less with the TTG transmitter, since it uses only one visual and one aural tube per side. Another benefit is that we now have the luxury of having two transmitters sitting there instead of one. This offers a lot more flexibility, since the system can operate effectively with only one side of the transmitter active, with only a minimum loss in coverage."

Remote Control System

In preparation for the new transmitting plant, a complement of test and terminal equipment was purchased in advance and checked out, including the remote control system and monitoring equipment which was set up and working six months before the transmitter was installed. The remote control system meters 30 functions; switches 60 functions, and also provides a status indication on 32 other functions.

The TV-13 remote control system operates on the signal subcarrier of the microwave STL system. "The transmitter has a subcarrier input, so we send it back as subcarrier on the aural transmitter; then we take it off the air and monitor without using any land lines," Mr. Moore explains.

The remote control system at the studio is rack-mounted near the Master Control switcher. Pushbutton controls turn the "A" and "B" transmitters on and off.

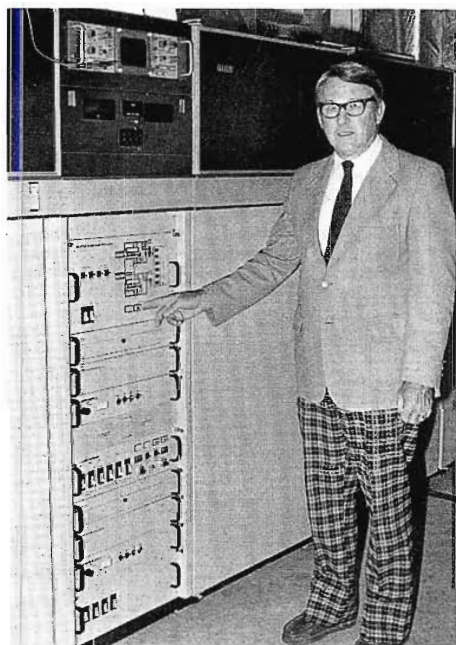

Bernie Moore operates load switch control on the paralleling cabinet of his TTG-30/30H transmitter. Available rack space has been utilized by TV-13 for mounting the test unit at the top of the cabinet.

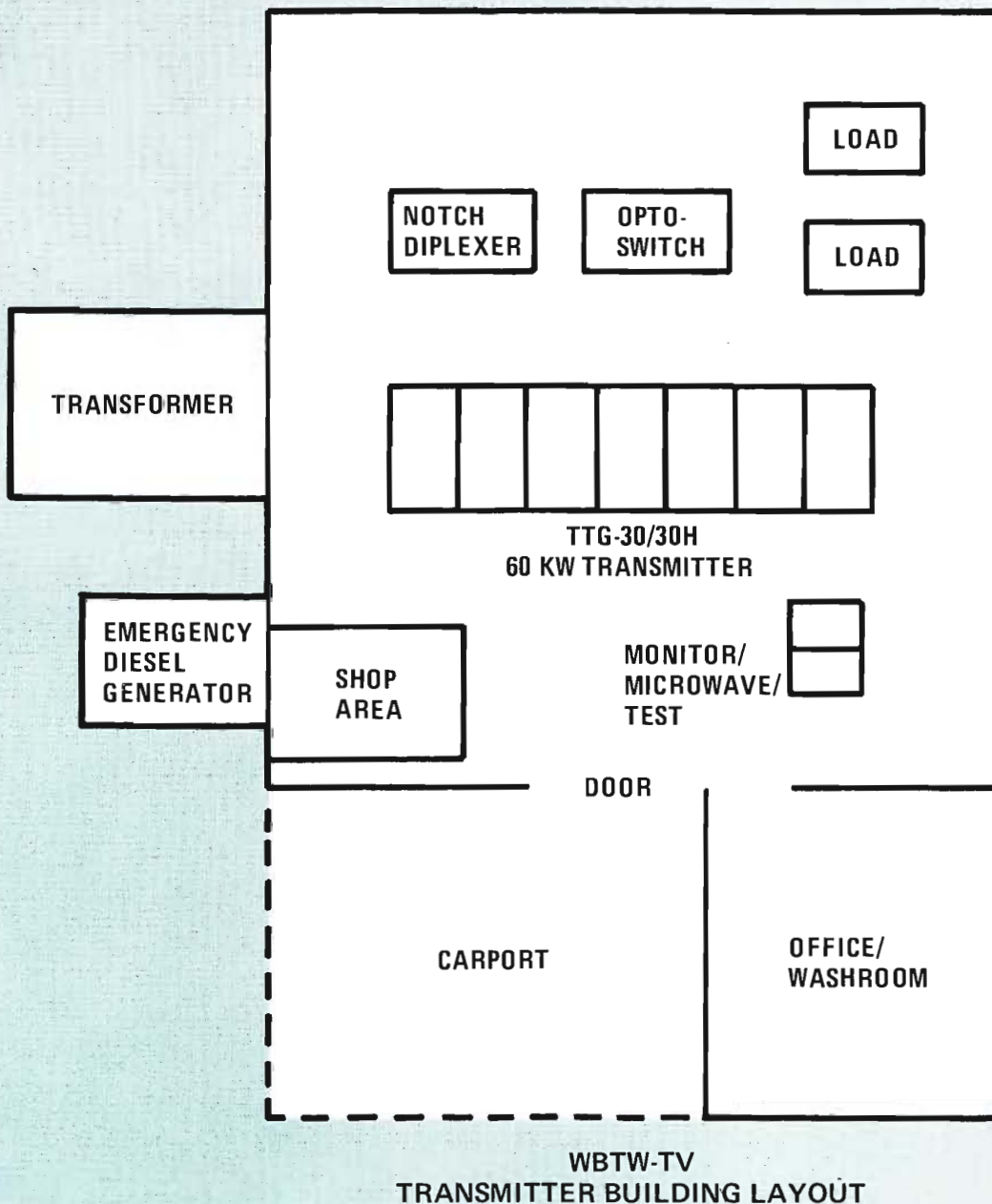

Sign-off is usually at 3:30 A.M., and sign-on at 6:00 A.M. The transmitter tube filaments are never turned off, Mr. Moore notes.

Transmitter Building Designed for Unattended Operation

The WBTW transmitter building is an unimposing cinderblock structure sitting in the middle of a working farm, and dominated by the impressive 2,000 foot antenna tower and its network of supporting guys.

The 30 by 40 foot building, Mr. Moore notes, was designed for a specific purpose: to house an unattended, remote operated transmitting system. To that end, it is a solid, windowless structure, with no roof openings, and no holes in the sealed concrete floor. One large steel dust-tight door provides access to the building.

The building interior has just two rooms: a small office area with limited kitchen/washroom facilities—and the remaining space for the TTG-30/30H parallel transmitter and its ancillary equipment.

The building was scaled to fit the transmitting system comfortably, with ample floor space allotted to permit walking around all floor-mounted equipment. This equipment complement includes the TTG cabinets; Opto-Switcher; Dummy Loads, and Notch Diplexer.

All conduit is exposed and is wall-mounted, and no plaster or flammable materials are used in the building. Since the facility was designed for unmanned operation, Mr. Moore sees no need for enclosing the front line cabinets of the transmitter to muffle the sound.

The roof is constructed of 8-inch concrete with reinforcing rods and hollow channels. Above this is insulation and roofing, which is topped by concrete paving blocks for protection against falling ice.

The hollow channels in the ceiling are used to anchor the hangers for suspending transmission line. These were laid out and positioned in advance, saving time during the installation period.

Air Handling System Provides "Clean Room" Environment

The 14-foot ceiling permits excellent air circulation, Mr. Moore says. He is particularly proud of the air handling facility. Outside air is drawn in at a second story level into a chamber located above the office area. The air is triple-filtered even before flowing through the filters in the G-line transmitters.

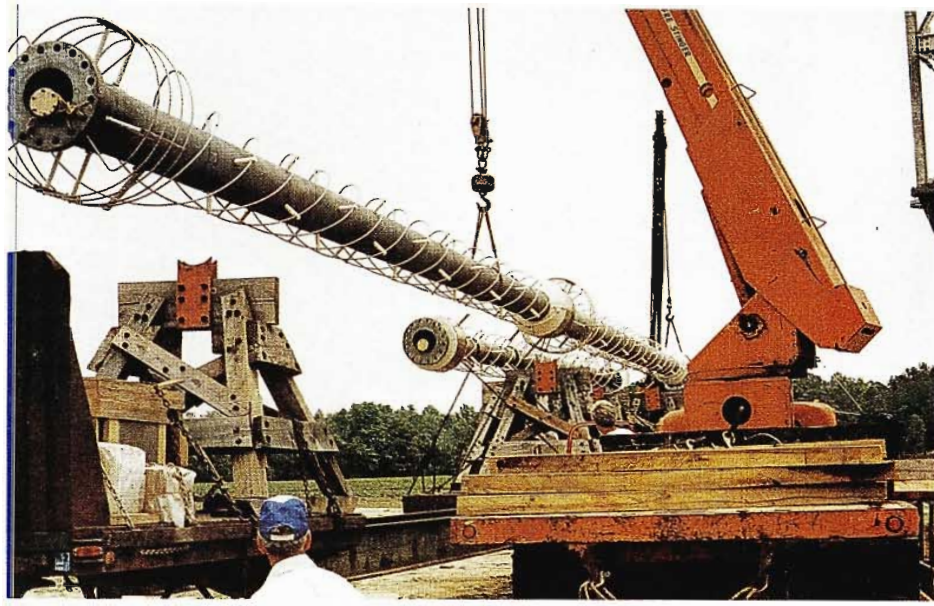

WBTW-TV's Tetracoil CP antenna was trucked from Gibbsboro, N.J. to the tower site at Dillon, S.C. in two pieces and was assembled on the ground.



It goes through an electronic filter, a roll filter, and then through the air handlers, directly to the transmitter room, without turns or ducts. The transmitter room is kept under positive pressure, and the air is absolutely clean. "I blow about twice as much air into the room as the transmitters take out," Mr. Moore states, "so I recirculate part of it. The recirculated air goes through the entire air filter system."

The air exhausted from the top of the transmitter is ducted to the outside, but can be diverted for heating the room during cold weather periods.

A 157 kW diesel generator is on hand for emergency power.

2000' Tower Erected in 28 Days

The contract for the transmitter building and the tower base was handled by Mr.

Moore. The 2,000 foot tower is sitting on a 24-foot by 24-foot base which is made up of 53 creosoted pilings 40-foot long, intermeshed with steel reinforcing rods and imbedded in six feet of concrete. This type of construction was required because the ground is sandy, with a high water table.

The tower is designed for a 65-pound windload, with three legs and nine layers of guy wires. Once the tower steel was delivered, erection moved at a swift pace. The tower was topped off 28 days after the steel was unloaded, Mr. Moore notes.

The 110 foot TCL-16A-13 Tetracoil antenna was shipped in two sections from Gibbsboro, N. J., and was positioned atop the tower without difficulty, after being assembled on the ground.

More To Come

With its new tall tower, circularly polarized antenna and transmitting system in place and performing as expected, WBTW-TV already is preparing to move ahead on the next phase in upgrading—the technical facilities at the studio. As a start, the retired TT-50AH Transmitter will be dismantled and removed, opening up a large area of floor space that will permit rearranging Master Control, Tape and Film operations. Bernie Moore and his small, dedicated staff are prepared for the new challenge. □

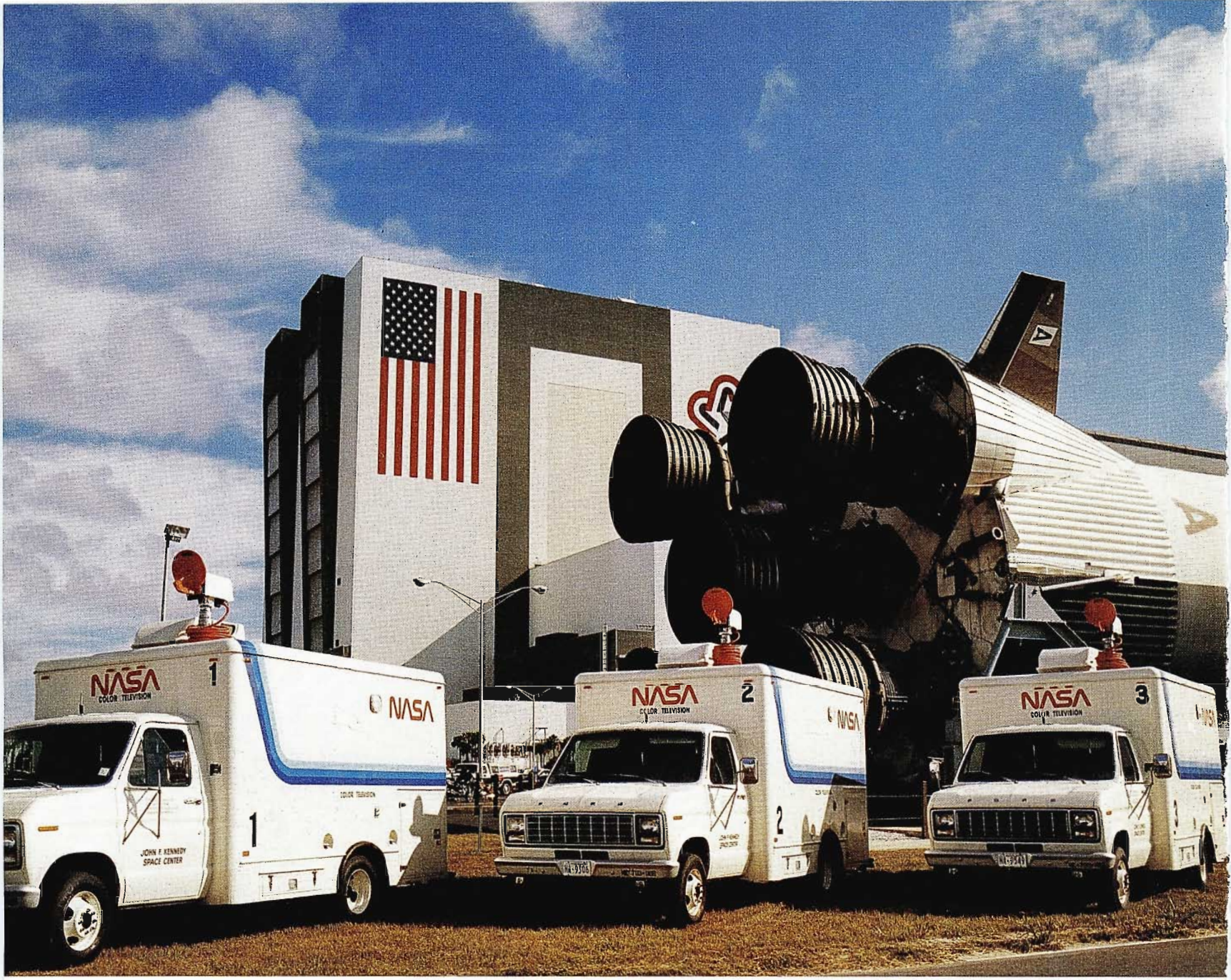

READY TO ROLL. Three mobile vans equipped with RCA broadcast equipment, sit in front of the VAB (Vehicle Assembly Building) at the Kennedy Space Center, Florida. The vans are part of NASA's (National Aeronautics and Space Administration) public information effort to bring the Space Shuttle operation to millions of television viewers.

NASA

TV Systems Ready For Space Shuttle Coverage

KENNEDY SPACE CENTER

While the planned Space Shuttle lift-off will be a well-covered media event, not all of the TV cameras present at the Kennedy Space Center will belong to network and local news crews.

A very important part of the coverage will be handled by a complement of RCA cameras manned by NASA operators and deployed from three new mobile vans.

NASA plans to record every facet of the historic Space Shuttle, the first manned vehicle designed to journey into space and then, like an airplane, return to Earth to be used again.

The Public Affairs Office will provide live and video taped coverage of the Space Shuttle and other launches for NASA's own use, for transmission to other NASA centers, and for release to the general news media.

A Nine-Camera System

Bringing all this information to the public will be seven RCA TK-76 portable television cameras and two TK-760 studio/field cameras.

Each of NASA's three new mobile broadcast vans, purchased and equipped especially to cover the Space Shuttle launches, houses a TK-76. (Public Information Officers hope to add a fourth van by the time of the first launch.) The vans will be stationed at various sites around the Space Center, including at Camera Site Four to record takeoff from directly in front of the craft, and at Camera Site 15 to track the space ship from four miles away.

During the Shuttle launches, four of the remaining TK-76 cameras will be stationary and remotely controlled. Two cameras with full capability, including pan, tilt and zoom, will be mounted inside the launch control center. Two will be stationary on the launch complex: one fixed 600 feet east of the launch pad focusing on ignition and liftoff; the other inside the White Room of the access arm of the Orbiter, the part of the Shuttle which looks like a commercial jetliner and carries passengers. Both cameras feature remote On-Off and White Balance.

"Inside" Coverage

"Our television capabilities are growing by leaps and bounds," notes NASA Public Information Officer Ed Harrison. "Our camera operators can get into areas where the news media cannot go due to security reasons. This will give the public an opportunity to see more of and learn more about the Space Shuttle than any other launch in the history of the space program."

Via RCA portable and studio cameras, millions of Americans will be allowed "inside" the mission director control center to watch activities right up to time of launch. They also will be able to follow the first Shuttle passengers on launch day from suit-up and breakfast, to the laborious three-and-a-half-mile trek to Launch Complex 39, and into the "White Room", the last access to Earth the space travelers will have before entering the Shuttle.

Covering A Launch

The launch of a GOES-D weather satellite provides a dress rehearsal for the NASA TV systems. The lift-off and pre- and post-launch activities give public information officers a chance to test new teleproduction capabilities in preparation for the main event—the Space Shuttle Launch.

"With the new equipment, we basically have a small television studio setup here," says Public Information Officer Gatha Cottee. "We'll be able to record just about anything that comes along."

They do for the GOES-D satellite launch.

The dress rehearsal for the broadcast equipment actually begins the day before the launch at a press briefing outlining the intricacies of the GOES-D weather satellite, the sixth Geostationary Operational Environmental Satellite launched by NASA for the National Oceanic and Atmospheric Administration (NOAA).

Press Briefing Documentation

As reporters fire questions about where the satellite will be stationed in space (above South America at 75 degrees west longitude) and why it is necessary (improved weather observation), NASA camera operators using two TK-76 cameras record the interaction between them and officials from the Space Center, NOAA and Hughes Aircraft Co., which built the spacecraft.

The press conference was recorded for documentation purposes, Mr. Harrison notes. Excerpts from it were used in an

eight-minute television segment shown pre-launch to NASA officials at the Goddard Space Flight Center in Greenbelt, Md. "This is the first time the entire color camera system has been used," he says. "We're experimenting with the cameras—deciding how we want them used in preparation for the Shuttle launches."

Cameras On The Go

On launch day, the cameras roll out bright and early to record activity at the launch pad. Six hours before launch time, a crew is dispatched to tape the roll-back of the gantry. The team then races back to the 52-story Vehicle Assembly Building (VAB), where the Shuttle is being built, to record for training purposes a subcontractor's three-hour lecture on piecing together the Orbiter.

"Our prime consideration is to cover launches," says Bill Johnson, Supervisor of RCA Color Operations who works closely with the NASA Public Affairs Office. "But we can handle any documentation or training that must be done, anything to do with audio-visual."

Johnson supervises crews that work in cooperation with the NASA public infor-

RECORDING LAUNCH. A camera crew, using an RCA TK-76 camera, records pre-launch activities of a Delta rocket set to carry a GOES-D weather satellite into space.



mation officers. "We're kept quite busy," he says. "The Kennedy news facility is the hub of audio-visual distribution for the space program. It is very seldom that the cameras are not in use."

"Set-Up Time Is Essential"

Although the TK-76 and TK-760 cameras were chosen on a competitive basis, he says their "dependability and operational ease" are a plus.

"When you have 35 men to coordinate you have to have something that's practically foolproof," Mr. Johnson adds. "Set-up time is essential for us. It's just like a regular news crew. We need rugged equipment that can take the wear and tear. We don't have time to set up for hours and hours and fuss with equipment. Because of the state-of-the-art cameras we're using today, we can do 10 times what we were capable of doing in the past with half the people in 25 percent of the time."

Three Identical Mobile Vans

"After the Apollo-Soyuz mission, it was decided to include the mobile van capability," says Glenn Routh, RCA Special Projects Engineer. "The three new vans are identical, each equipped with one TK-76 with a TK-760 control unit, and a four-input audio mixer." A pneumatic-controlled mast mounts the antenna used for microwave transmission. The receiving dish is mounted atop the Vehicle Assembly Building. One camera will also be positioned there for the Space Shuttle launches to track the craft, Routh says.

Live coverage of the launches will be provided by NASA to officials in Washington and Houston, and to the three major U. S. networks, and to the European Broadcasting Company or a network pool.

The capability of going remote with the mobile vans is a real plus, Public Information Officer Harrison notes. "It is great that we can get away from the cabling we had to use in the past."

Multi-Purpose Cameras Are Fully Utilized

Even when Public Affairs activities slow down, the cameras do not sit idle, Mr. Harrison stresses. "Providing live and video taped coverage of the launch activities is only part of the story. The cameras serve a multitude of purposes for us."

Three of the TK-76 cameras were used to support the assembly of the spaceship Columbia, the first Space Shuttle craft, by providing quality control surveillance.

Like a mammoth jigsaw puzzle, the exterior of the Columbia is made up of 31,000



ON-SITE TV. NASA public information officers at Kennedy Space Center are using seven RCA TK-76 cameras and two TK-760 units for training, quality control, and to record launch activities. Three mobile TV vans will be used to record all phases of the launch of the Space Shuttle.

tiles which will keep the craft from burning up upon its re-entry into the Earth's atmosphere. Each of these must be expertly glued and popped into place.

The tile placement was a complicated procedure. It took up to an hour to dab on the glue and position a tile, but the whole process took much longer.

Tiles Video Taped For Quality Verification

To reinforce the tiles, they were coated with a solution of liquid glass and then baked in a kiln at 400 degrees. They were tested and bonded with a protective pad on the spaceship, a process which took more than 24 hours.

The cameras were used by NASA as part of its quality control program. Each tile was individually video taped for verification, explains Dick Burns, RCA field systems specialist, video engineering group. "The TK-76 cameras provided the resolution needed to detect the hair-line fractures which could spell trouble if they went uncorrected."

TV cameras were used to monitor every step of a tile's history. Each tile had its own file filled with necessary data on how it survived rigorous testing. The cameras will be used in this capacity right up until 12 hours before the Shuttle Launch, Mr. Burns notes.

The NASA Camera Shuttle: Launches; Training; QC—And More

The RCA cameras also play an important role in the training of workers piecing together the puzzle that is the Space Shuttle. "If there is a lecture or a series of lectures—be it someone behind a lectern for a couple of hours or an 80-hour training course—we can record it for our subcontractors and use the information again and again," Mr. Harrison says.

From television news coverage of a launch to quality control . . . to training and documentary production, NASA's busy TV cameras and mobile units do their own version of the shuttle in performing the variety of assignments they're called on to handle at the Space Center. □



At an on-site training seminar at the Kennedy Space Center, Bob Hurst, an instructor at the RCA Technical Training Center, discusses one of the TK-76 camera modules.



The active interest by the government of the state, the benefits of clean, clear air and blue skies, and the availability of experienced, professional personnel has established the State of Florida as a leading production center. To serve the multitude of producers seeking to take advantage of the Florida scene, Video Base Florida has established under one roof a total service, professionally staffed and equipped production facility.

Reputed to be the largest total service video tape facility in Florida, Video Base offers film, audio and video producers complete service from location or studio production to distribution of the final product.

Hollywood, East

Video Base, located at 2053 Lee Street in Hollywood, Florida, is a home away from home for visiting producers. The attractive, modern facility is the result of the current boom in production in the Miami area. Rusty Hancock, Vice President of Video Base, remembers the previous facility and operations, "Most of our work at that time was in 16mm film. We were operating from a small studio on Hollywood Boulevard. It didn't take long for us to realize that there was a rapid increase in the need for video production in our future. My father has been in the radio and television business all of his life, working as an announcer, producer and commercial writer. During

**FULL SERVICE
FACILITY FOR
PRODUCERS
SEEKING A
CREATIVE
CLIMATE**

HOLLYWOOD, FLORIDA



Sunlight and blue skies greet the visitor to the Video Base facility in Hollywood, Florida.

those years, he had acquired considerable work experience with RCA broadcast equipment. It seemed like the natural thing to do to come to RCA to design, build, and equip our facility." The planned installation in the Hollywood Boulevard location was changed to the new location on Lee Street when space limitation and an ambitious expansion program were realized.

RCA's Broadcast Systems was employed for total implementation of the Video Base facility. Equipment was selected and, in some cases, modified to meet the specific and demanding needs of the Video Base staff. The RCA Project Implementation staff coordinated the ordering, arrival and installation of the equipment. The original selection of RCA to guide the project was due to the faith of Video Base in RCA's equipment backup reputation because, at this point, there was a limited technical staff on board. In order to facilitate the installation process, RCA Project Implementation designed and installed electrical, compressed air and air conditioning fixtures prior to the completion of the construction. Upon arrival, the equipment was simply hooked up. Outside contracted engineers worked with RCA to determine a proper air conditioning environment for the equipment. Video Base has installed a secondary air conditioning system for the equipment to provide backup in the case of central air conditioning failure. In the hot climate, this is a real worry saver for producers.

Video Base is a 25,000 square foot producer's facility. It was in operation even during the final phases of equipment installation. Whether utilized by film, video or audio producers, Video Base is equipped to handle the job. The 60 by 50 foot studio dominates the facility. A 30 by 50 foot cyc provides a multitude of limitless backgrounds. An RCA TK-76B equipped with a 14:1 Fujinon zoom lens is the standard camera in use. Utilizing

a quick conversion kit, this camera is available as an RCA TK-760 studio/EFP camera equipped with RGB chroma key that, according to Greg Fox, Technical Supervisor, "worked right out of the box." Video Base Director of Photography, Dave Englund, is looking forward to increased production use of the TK-760 because of its more precise mobility in studio conditions and easily viewed five inch monitor. Adjacent to the studio are a scene shop, vehicle preparation area, vehicle storage area and talent dressing room.

The engineering room and editing suite are conveniently located for increased production flow. Engineering offers the latest in professional video equipment. Video tape recording is done on Video Base's two TR-600 Quadraplex VTRs or the RCA TH-200 one-inch helical scan recorder. A telecine island comprised of an RCA TK-28C saticon equipped color camera with remote color correction capability, a TP-7B slide projector and an RCA FR-35 35mm film projector occupy the remainder of engineering. A temporary 16mm film projector is in the position reserved for an RCA FR-16 16mm teleproduction motion picture projector.

The editing suite doubles as master control during production sessions. The

Michael Garrett, artist and scenic designer, prepares a storyboard layout for an animated commercial.

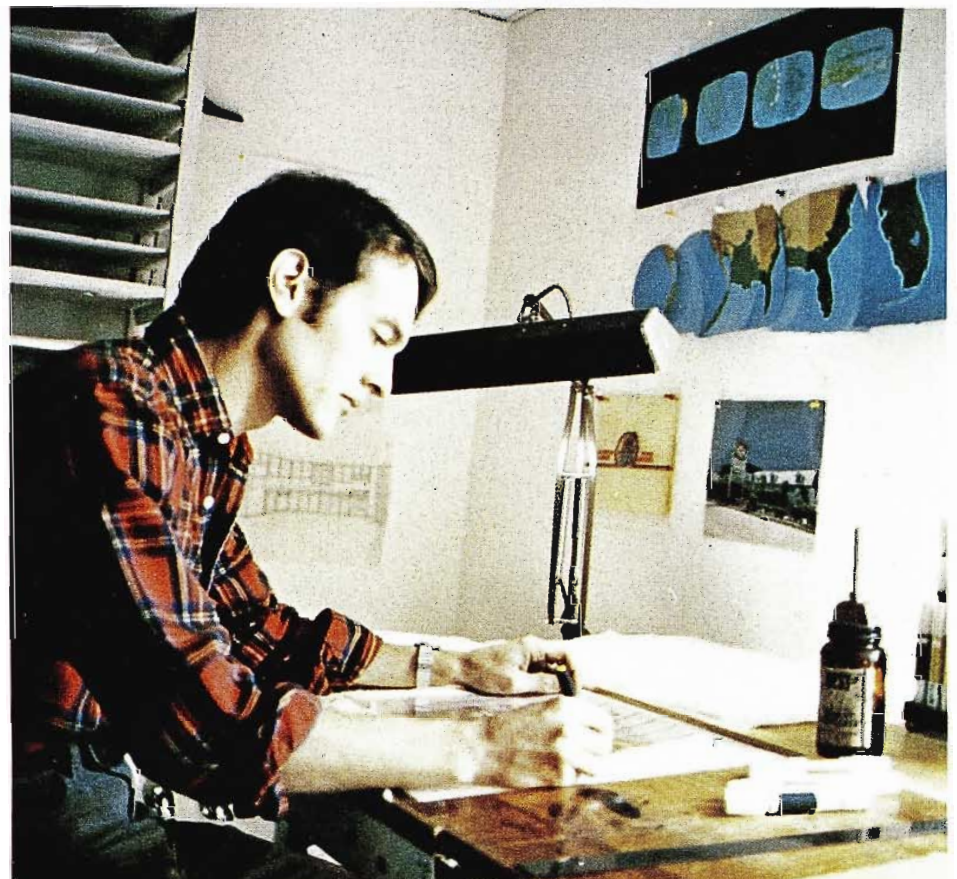

heart of the control system is a Vital 114-10A production switcher featuring spin and rotary wipe effects. Time code computer editing is accomplished by a Data-tron Tempo 76 series editing unit. Audio feeds are through a custom MCI audio board. Audio recording can be accomplished directly on video tape or on the eight track audio recorder. This audio recorder interfaces with video tape time code and provides the capability of complex, synchronous audio mixes to video tape.

At Video Base Florida, the talent and other human elements are as important as the hardware. Kitchen, dining and recreation areas are provided for relaxation while the production teams are changing the set-ups or preparing a shot. Screening room and conference areas are available for creative sessions.

The Video Base crew has acquired extensive experience in film and has not ignored that portion of the production industry. Film cameras (Eclair NPR), grip equipment, editing and animation services can be hired by a film producer. As on the video side of the business, the film equipment can be supplied with or without a crew. Supporting the camera and lighting crews are total in-house services for scenic design, art and engineering.



Threading an RCA PM-86SL, Tom Gasek prepares for a sound transfer session.



Cast, crew and two RCA TK-76s take their positions for the rehearsal of an AMC training production in the large Video Base studio.

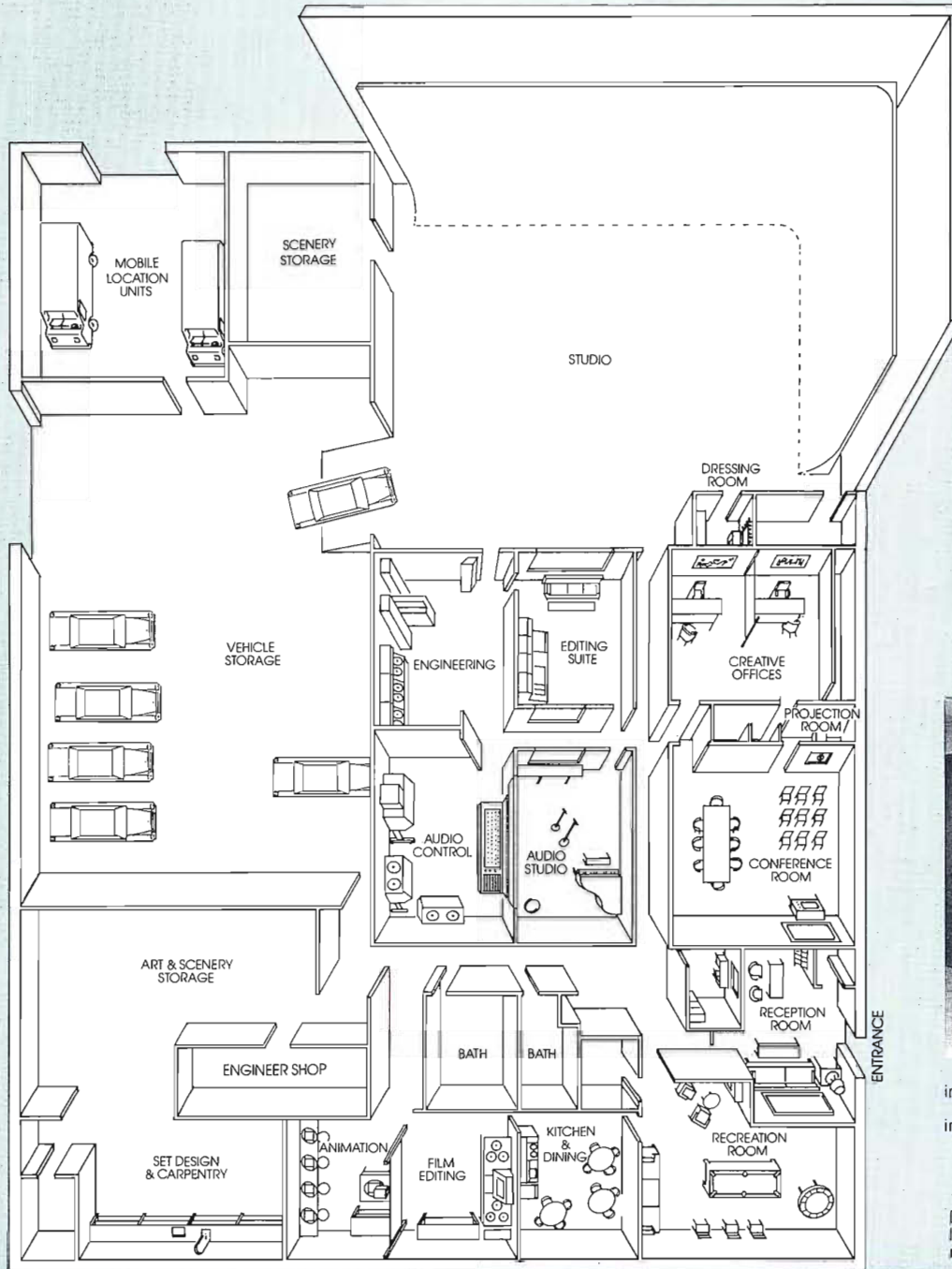

Greg Fox, Video Chief Engineer, maintains the high quality of equipment standards and operation. Here, a TR-600A quadruplex VTR is set-up to facility requirements.



Audio quality and control is extremely important at Video Base. Complex mixes for video are handled through a time code interlock of audio and video tape recorders.

During a break in production, Peg Woehl lines up a shot in the Video Base recreation room.



Video Base's film editing capabilities serve both the 16mm and 35mm producer.

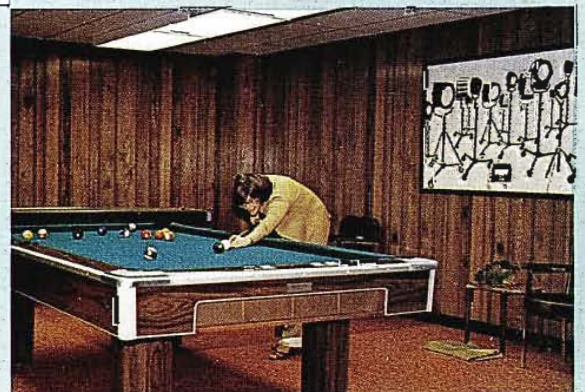



On location with the TK-76B, Director of Photography, Dave Englund, lines up a shot for a local production.

On location

Taking advantage of the ideal production climate of Florida, the Video Base team often finds itself on location. Most video work has been done with the RCA TK-76B and an RCA TH-50 portable helical scan VTR. "We often work under quite humid conditions," commented Greg Fox, "and both units have worked quite well. The TK-76 is moisture and fungus proof. I feel really good about the reliability of our equipment and am especially confident knowing that RCA's Tech Alert is behind each product. They're the great savers . . . always there to bail us out if we have a problem."

Fox feels exceptionally confident of the training that he has received at RCA's Camden, New Jersey, headquarters. "Most recently, I've attended the TK-76 session. Everyone involved has been really helpful in providing me with product information. If I have a special situation that I feel is unique, there is no problem in arranging a discussion with the product and engineering people responsible for that piece of equipment."

Local Topeekeegee Yugnee Park has served as the location for several Video Base productions including a health food chain spot. Acting as cameraman, Dave Englund relates his extensive film experience to his recent video work. "I enjoy the spontaneity of video. Both the client and I are sure that what we shot is the quality and image we wanted." Greg Fox adds, "I am very satisfied with the image quality that the Saticons in the TK-76 are providing." Wearing the hat of chief cinematographer, Englund states that the Video Base often uses film for location work. Instead of then waiting to see how the lab handles the various stages of printing, the work print is transferred to video tape. This is ideal for the producer who wants the look of film and the faster turnaround of video tape. The transferring of film to tape has become a major enterprise

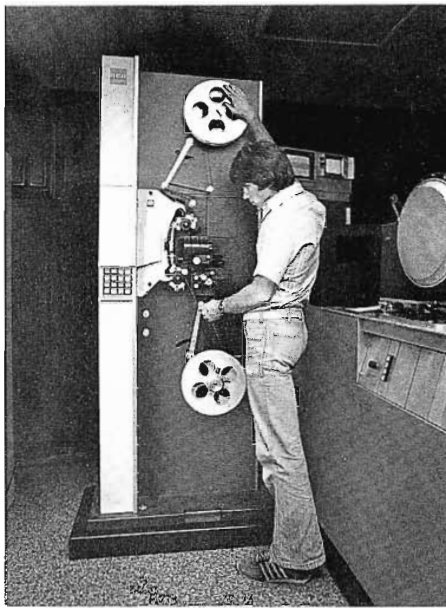

Steve Fraasa loads the RCA FR-35B with negative film to be transferred to three-quarter inch video cassette.

for the RCA equipment at Video Base Florida.

"Negative handling? . . . no problem!"

The Video Base location has become the gateway to South America for televised media. For that reason, the company has been quite active in transferring feature length 35mm and some 16mm film to video cassettes. These cassettes are for on-air use and must therefore be of top broadcast quality. Comments Rusty Hancock, "The TK-28 island runs almost continuously during these long transferring sessions. We're convinced that we are able to provide almost perfect color correction. Better than that available in a film to film transfer."

Video Base suggests that producers who plan to transfer 35mm to tape provide them with an uncorrected negative, or a one light work print. "It makes sense that a better transfer is obtained from an uncorrected original," states Hancock. "Adding corrections to already corrected generations of film often compounds a problem." Producers need not fear turning precious negatives over to Video Base professionals and their RCA FR-35B. "We've done considerable negative transfer to tape," reflects Rusty Hancock, "The FR-35B is a nice projector, handling negatives with no damage." Greg Fox adds, "The FR-35B really

handles film well, undoubtedly due to the C-MOS logic."

In addition to the South American productions, much transfer work is being done for the Middle East and Mexico. Although rarely correcting color on a scene by scene basis, enough color correcting is done to require the remoting of the operating controls. The 50 foot remote control run to the editing room was designed and executed by technician Fox and has greatly facilitated many sessions. Local producers have employed the telecine color correcting capability to improve 35mm transparencies that are projected into the TK-28 through an RCA TP-55 multiplexer by the TP-7B slide projector.

Indoor production

The Video Base studio is ideal from every angle of the production viewpoint . . . talent, producer, lighting director and cameraman. Adjacent to the studio is a dressing room for quick costume changes. Using the TK-76 at light levels lower than those required for film enables the studio to be maintained at a reasonable temperature. That low light level also allows lighting director Englund "to achieve a very pleasing look, especially in the diffused lighting environment that we work in for the numerous automobile commercials that are produced here."

Englund has been creatively using the operational features of the TK-76 to enhance picture quality while at the same time keeping a production moving. During a recent American Motors Corporation training tape shoot, Englund utilized the White Balance control to balance the TK-76 to a rented camera that was brought in for the production. Lighting the multiple automobile set was facilitated by a catwalk behind the cyc and an overly adequate, custom light grid that provided the ultimate in light source control.

Once tape is rolling, the scenes are marked by a pair of RCA TC-1005 slate

Video Base's versatile tape mastering capability is a key to attracting producers. An RCA TH-200 one-inch VTR awaits the command to roll as Steve Fraasa sets up one of the two RCA TR-600 quadruplex video tape recorders.



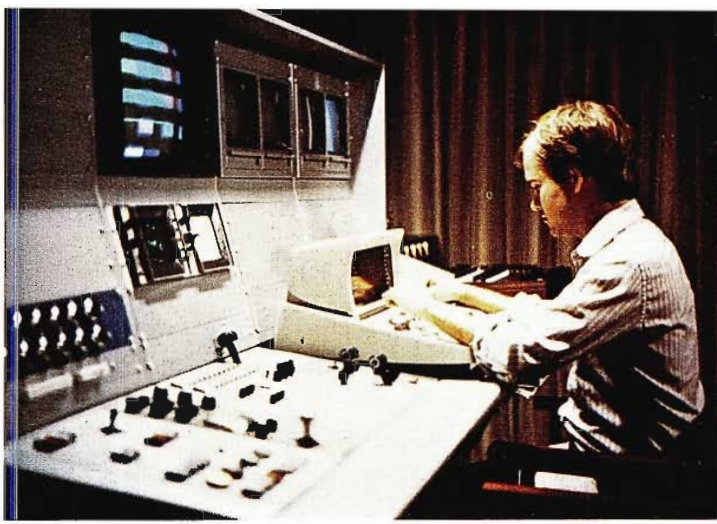

Rusty Hancock, Video Base Vice President, takes an active role in production. The RCA-supplied Datatron Tempo 76 Time Code Editor is employed here during a post production session.

cameras. These black and white cameras are locked to the house signal and one is equipped with an electric zoom for effects. Joining the slate cameras in master control will be the Camera Control Unit for the TK-760. The installation of this unit has been modified by Greg Fox to adapt to the Video Base facility.

Controlling the editing and insert work at Video Base is an RCA installed Vital switcher joined with a Datatron editor. The system is currently operating such that in production the master tape recorder may be either the two-inch TR-600 or the one-inch TH-200. During editing, the TR-600 is the master machine providing a two-inch quadraplex master. The TH-200 is creatively employed to provide special effects like variable motion. Always seeking to provide clients with the best looking productions, the Video Base production team has even employed the TBC-200 digital time base corrector to create numerous effects like the "Hall of Mirrors."

While Video Base Florida was being conceived and during the installation period, the world of Type C, helical scan recording was rapidly growing and improving in reliability. "We are very impressed with our TH-200 and the capabilities that the one-inch format offers our clients," remarked Rusty Hancock. "The producers are the key to our increased involvement in the one-inch format. As they begin to request one-inch recording, we will be ready with increased recording, production, and editing facilities."

Because of the role the TR-600s play in the mastering of productions at Video Base, both Rusty Hancock and Greg Fox see a virtually undiminished importance in the work load of the quad machines. Comments Greg Fox, "The TR-600s are really the work horses of the operation. They stand up to many punishing operations, including some tough animation sessions (see boxed insert). One TR-600 already has 400 hours on it in recording operation."

Full service facility with planned growth capability

The Video Base facility has been designed and constructed to expand with the growing Florida production business. As it now stands, over 10,000 square feet are allocated for a second studio and additional video tape editing rooms. Space for the additional personnel required has also been planned. This room to expand has instilled a motivation to increase business and continue to attract producers interested in a first rate production facility.

The in-house creative team of Rusty Hancock, Vice President, Tomas Gasek, Art Director, Greg Fox, Technical Supervisor, and Mike Garrett, Scenic Designer, has opened the world of video animation to the moderate budget producer. Utilizing the TR-600 quadraplex video tape recorder and Datatron Time Code Editor, a series for a local bank became the first commercially produced spots utilizing a Video Base developed procedure to animate 3-D characters. Comments animator Tomas Gasek, "Video has added an entirely new element to animation that we never had in film. That is the human element. We can create, adapt and add as we animate, then see the result immediately." Here's a summary of how the effects are achieved as described by Rusty Hancock.

"The first step that we go through is the recording of the character voices. This recording is transferred from quarter inch tape to 16mm magnetic film on the PM-86SL. At this point we are able to break the voices into phonetics and reference the sound to 24 frames per second and then convert it mathematically to the video tape speed of 30 frames per second. Tom Gasek now prepares the facial expressions for the clay three dimensional characters to match the phonetic elements. We are now ready to record using our TR-600. The control track and audio are pre-recorded on two-inch tape. The TK-76B has been providing fantastic color rendition as our animation camera. The TK-76 is established as an external source with the TR-600 operating in an insert mode. Using the Datatron Tempo 76 Time Code Editor, we control the TR-600 to record two frames per clay character move. This is accomplished by pre-rolling the tape for five seconds, shifting in record for two frames, then cutting out. Utilizing the time code as reference, we advance two frames at a time for an animation effect smoother than most film animation. All in all, it takes about six hours to complete a thirty second animated spot."

Video Base has also been experimenting in cell animation with the TK-76 on a horizontal animation stand. Comments Tom Gasek, "The colors and images have been so clear. Video animation is certainly an emerging art especially when it can be made available to the moderate budget market."

The use of 3-D and cell animation has evolved as a viable commercial product at Video Base through the perfection of the technique. Constant experimentation in new animation processes at Video Base Florida will mean more unique production capabilities for producers.

Newly acquired RCA cameras and production equipment will serve a double duty in the studio and aboard the new Video Base mobile van. Remarks cameraman Dave Englund, "Although we have been active in remote productions, the acquisition of a mobile van will add a new dimension to our production capabilities."

Video Base Florida was conceived as being Florida's number one full service production facility for film, audio and video. The fact that it has done work for clients from New York City, Texas, Oklahoma, the Middle East, South America and numerous local producers in the Miami area establishes the successful, professional attitude at Video Base. Sums up Rusty Hancock, "Our goal will always be to provide complete facilities and service to producers, their talent and their crews. Video Base provides a friendly place for people to work and a totally professional atmosphere."

A visit to Video Base Florida is always started with a warm greeting and a hot cup of freshly brewed coffee. □

Video Base Florida opens a new world of video animation

Three dimensional animation at Video Base goes through many diverse, complex steps. Here, Tom Gasek prepares 3-D animation set...



... under the watchful eyes of Rusty Hancock (center) and cameraman, Dave Englund.



VIRGINIA BEACH

CHRISTIAN BROADCASTING NETWORK'S NEW CENTER



A Technologically
Advanced TV Production
Facility

The new headquarters complex of Christian Broadcasting Network in Virginia Beach, Virginia, represents another benchmark in the on-going growth of this popular television ministry headed by Rev. M. G. "Pat" Robertson.

Much has been written about the impressive colonial architecture of the new Center, and of the expansive plans for its utilization in enlarging the television reach of CBN. Less attention has been focused on the technical areas of the building which provide the capability for expanded program production and distribution. The technical facilities are also most impressive.

The CBN headquarters building itself symbolizes the mission of its occupants. It is a cross-shaped structure, with a circular prayer chapel in the center, public areas in the front, and the technical operations at the back.

Pat Robertson and his wife Dede planned the overall design and decor for the public areas of the building. The responsibility for planning and equipping the technical areas fell to Jerry Horstmann, Production and Operations Director, and to Sam Tolbert, Director of Engineering.



(Mr. Horstmann has since been named to head Programming for CBN.)

Planning The Technical Facilities

Their mission was straightforward: to provide a state-of-the-art technical facility for CBN that was cost-effective and capable of expansion to accommodate future production needs.

In developing their plans, Horstmann and Tolbert visited numerous facilities in the U. S. and overseas to become familiar with the latest trends in design, layout and technology. Extensive discussions were held with various equipment suppliers.

Jerry Horstmann concentrated his efforts on lighting, studio, scenic and other production/operation-related facilities, while Sam Tolbert focused on the technical equipment and system requirements. The equipment complement was determined by projection needs, and the equipment list was drawn up in advance of the room design, Mr. Tolbert noted.

The completed and operational CBN Technical Center is both state-of-the-art and ready for future production demands.

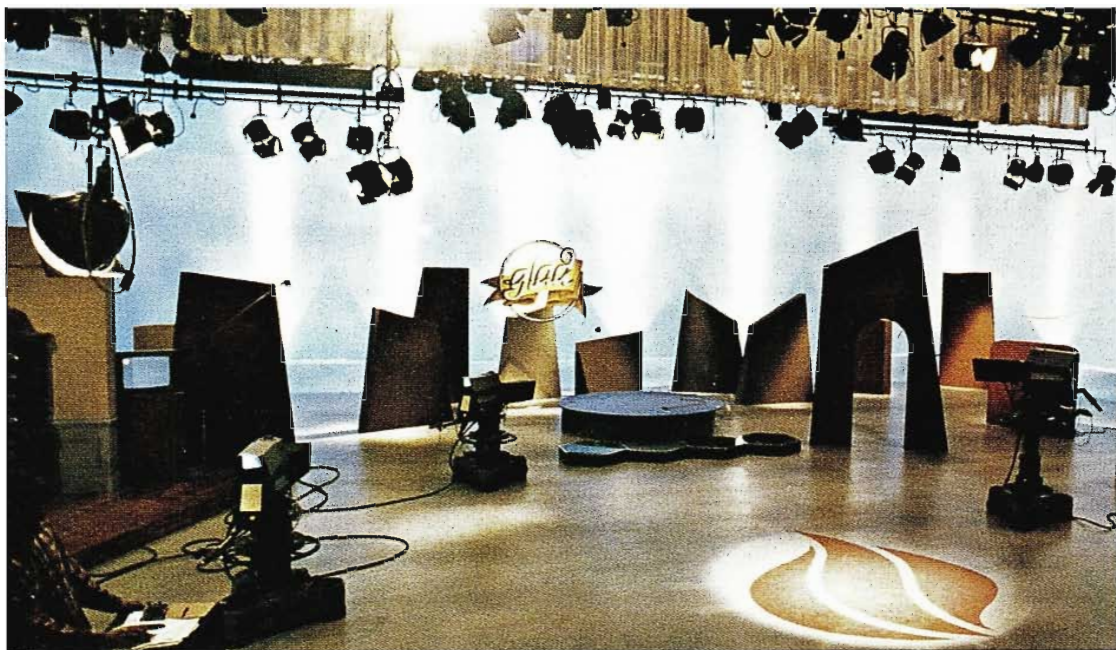

The two identical main studios feature a digitally controlled grid system for lighting and scenery.



Video control for the two main studios are also identical. Camera controls for eight TK-47 cameras and two TK-760's are mounted in each of these video control consoles.

Four Studios

In the technical area are four television studios and a complement of production control, engineering and support facilities. Two of the studios are identical in size and equipment: 11,766 square feet, with seating for 382 spectators. One of these, designated Studio 7 is used for originating the 700 Club program, a daily 90-minute production.

Eight TK-47 Cameras For Studio Production

Eight TK-47 automatic color cameras are available for studio productions. Four are usually assigned to each of the main studios. However, camera remote controls for all eight TK-47's are mounted in video control consoles in each studio. In addition, remote controls for two TK-760 cameras are also mounted in each console. This flexible arrangement permits using all cameras in one studio and controlling them from a single console position. The console is large enough to accommodate up to three video operators and can handle twelve cameras. A waveform monitor and vectorscope is provided for each camera, and each video control position is equipped with a basic switcher to permit the operator to preview each camera's output before putting it on line.

"A State-Of-Art Camera Design"

One reason for the selection of the TK-47 cameras was CBN's previous good experience with RCA cameras, according to Mr. Tolbert. In addition, the camera met the criteria set out for equipment purchased for the new Production Center: "It is a state-of-the-art design; a digital system, and its automatic functions and microprocessor-controlled set-up readily translate into savings in time and manpower in set-up routine," Mr. Tolbert adds.

"Auto Check" Verifies Camera Stability

The TK-47's are given the "Auto-Check" pre-operational check daily, although Sam Tolbert notes that the stability of the cameras has been such that the daily check merely verifies the stability to the video operators. Initially, cameramen and video operators were skeptical of the TK-47's stability and set-up capability, particularly for achieving optimum settings quickly and automatically. The camera's excellent performance without manual "tweaking" of controls succeeded in turning the skepticism into confidence.

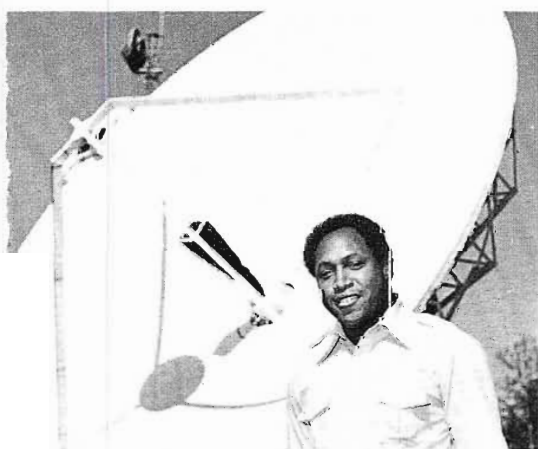
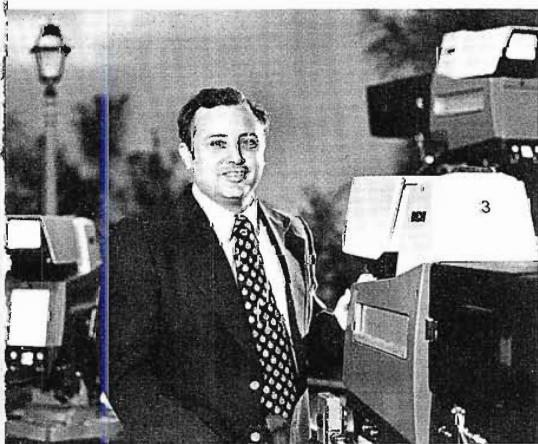

Planning CBN's new technical facility was a joint responsibility of Jerry Horstmann (top), then Director of Production and Operations, and Sam Tolbert, Director of Engineering.

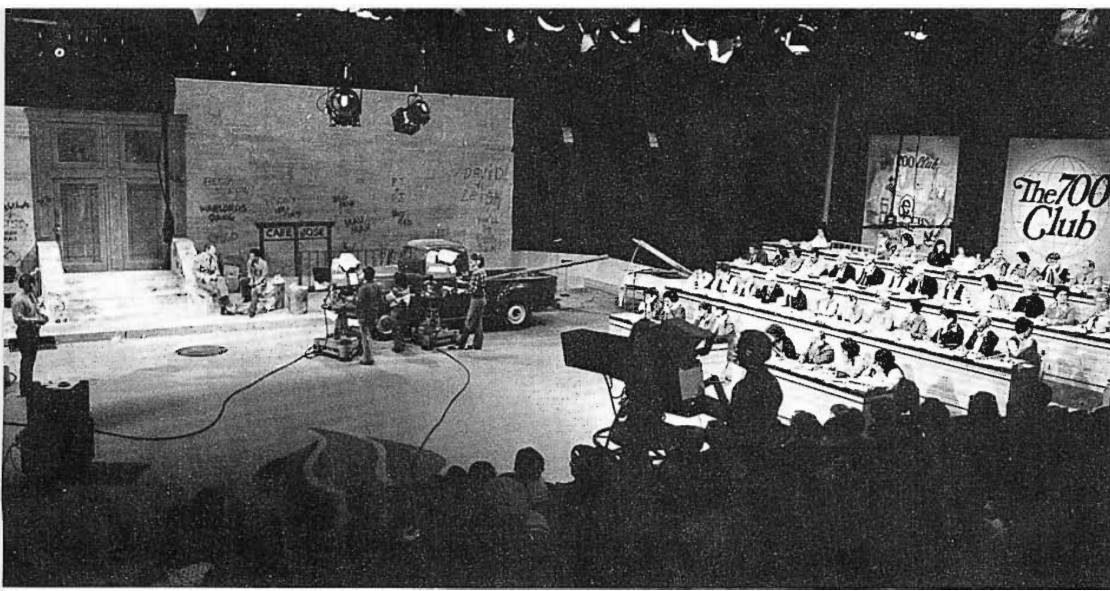

Studio production for "The 700 Club" involves four TK-47 cameras. Seating is provided for the telephone counselors (right) and for a studio audience.



Co-hosts for the popular "700 Club" are Ben Kinchlow and Rev. Pat Robertson, shown on set.

"700 Club"—A Daily Live Production

The four TK-47 cameras assigned to Studio 7 are customarily used for the "700 Club". Produced daily on weekdays before a live studio audience, the "700 Club" continues to be the mainstay of CBN programming. Hosted by Pat Robertson and Ben Kinchlow, the magazine-format production intermixes music, news, lively interviews and special features.

Broadcast live and transmitted by satellite, this 90-minute program is a demanding production assignment, since it uses numerous inserts of pre-recorded material as well as live inserts received via satellite. Currently the "700 Club" is broadcast on 162 television stations in the U. S. (42 of which receive the programs live via satellite). More than 1800 cable systems also carry the program on a regular basis.

Identical Production Control Rooms for Two Main Studios

Technical areas at the CBN Center are glassed-in, permitting visitors to view the operations without disrupting them. The facility is designed to accommodate five control rooms. Two of these are now in place; a third in process; and two more are planned for future expansion.

There are two identical production control rooms for the main studios—Studio 6 and Studio 7. These are generous-sized spaces which include lighting control and remote camera control positions as well as video switching; machine control, and graphics. Adjoining Production Control is an audio room which is equipped with a Neve console customized for television production.

The Production Control console is also custom, designed and built by CBN (a product of their large, well-equipped Scenic Department). The console includes a Grass Valley 1600-7K video switcher with E-Mem and digital video effects. A waveform monitor and vector-scope are desk-mounted in front of the Director at the center of the console, providing a continuing check of output quality.

To the right of the Director's position on the console is a computerized Machine Control unit designed by CBN. This system permits accessing all video and film machines from keyboard/display monitors in each Production Control room and other selected areas. Controls removed for the VTR's are "Stop-Start" and "Slo-Mo".

A Vidifont titling generator is located in each control room and in each editing suite. Telephones on the console are recessed out of the way, and are equipped with retractable cords, eliminating the clutter of phone wires on the desk space. As an added convenience, all console positions have track lights overhead which permit individual control of lighting levels to suit the operator.

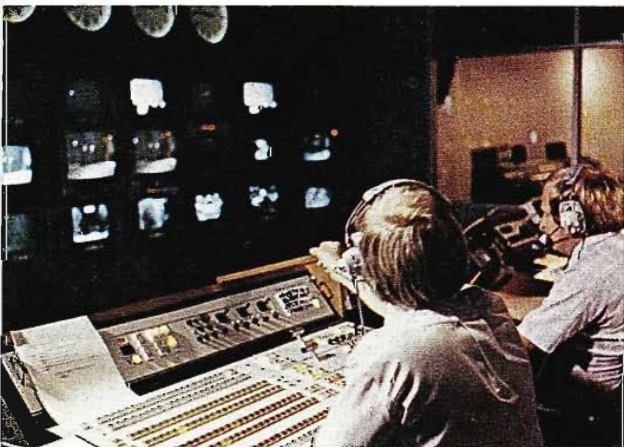

Production control positions for the two main studios are identical.



Customized audio console occupies a glassed-in space adjoining Production Control.

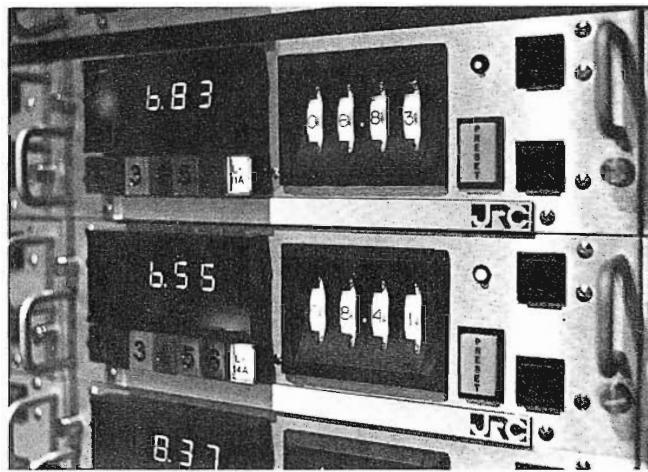

First Digitally Controlled Studio Grid System

CBN prefers to have the lighting control and video camera control operations located in the same area, since their functions are closely inter-related.

Next to the Lighting Control positions in Studio 6 and Studio 7 Production Control rooms are banks of LED displays which identify the exact position of the individual grid battens for lighting and scenery. This installation is the first digitally controlled system for raising and lowering battens. It provides unusually close control settings—within 3.18 mm (1/8-inch). All measurements in the CBN Center are metric for compatibility with world standards, Jerry Horstmann notes.

The studio grid in Studio 6 and Studio 7 is comprised of a total of 109 battens. Scenic battens alternate with lighting battens, at one-meter intervals, each individually controlled by a motorized winch. A computer memory system stores the exact location of each pipe, and these are shown on LED displays in Production Control.

As many as 53 different pieces of scenery could be flown at one time.

This system, Jerry Horstmann notes, was more expensive than the conventional counter-balanced system. However, the additional cost is readily justified, since the motorized winch system saves half the weight of the counterbalances. And, more important, it saves 400 square feet of valuable studio space. Substantial savings in manpower are realized also, since the lighting director can handle changes from the Production Control room without need for stage hands. Mr. Horstmann estimates that the additional cost for the system will be recovered in the first two years of operation.

Computer-Controlled Lighting System

The lighting system at CBN is also computer-controlled. The lighting board uses

Computerized lighting system can be controlled from the Lighting Control console in the Production Control room. Lights are pre-set, using motorized controls and memory system. Position of each of the 109 grid battens is displayed on LED readouts in Production Control.

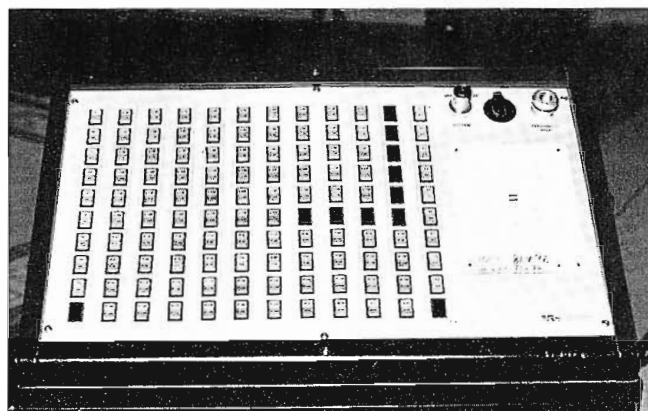

a pin patch with one dimmer per circuit, and a total of 846 dimmer circuits in each studio. This system, too, was selected for versatility and savings. Dimmer circuits are set up so that the power usage is directly related to the light output of the fixture. No ladders are needed for trimming lights.

Studio Design Features Save Production Costs

Reference chips on the studio floor permit exact positioning of scenery and lighting. Using the studio floor plan with reference chips identified, the scenic designer can spot the selected location of each set piece and provide a layout to the Lighting Department. With this layout

and an overlay of the lighting battens, the lights can be pre-set, even before the set is constructed. When the sets are completed, stage hands can position them precisely and quickly. Considering the ambitious programming plans projected for the CBN studios, substantial savings in production time and cost will be realized with this system.

Another interesting facet of the studio design is that there is no heating system for any studio—only air conditioning. Hot air from the studio lights is reclaimed for heating other areas of the building.

Since telephone call-ins are a part of the CBN programming format, the main studios were pre-wired to handle up to

Students at CBN University, a graduate school, develop their television production and programming skills by producing their own weekly program.

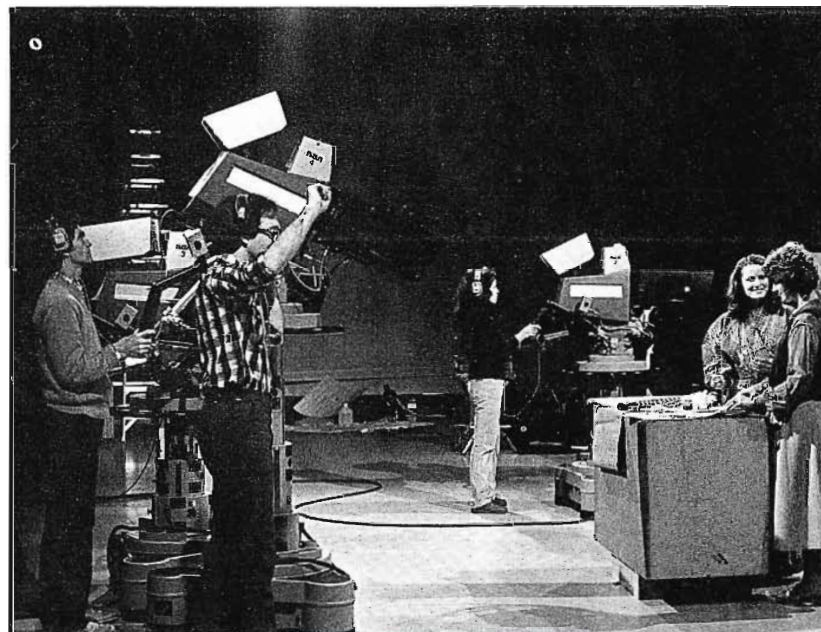

600 phones. With this arrangement, the telephone company can handle the phone set-up in a half a day rather than the two days formerly required for this service.

Technical Operations Area

This space houses the quad, 1-inch and 3/4-inch VTR's and other technical facilities, including editing, audio and video tape duplication, telecine and program continuity control. The operations area is open, yet compartmented, with extensive use of movable glass partitions for visibility, and the utilization of equipment for interior "wall" dividers. The eight quad VTR's, for example, are arranged in a line so that their rear cabinets provide a hallway "wall". This saves valuable space, while providing excellent access to components for maintenance. Computer flooring is utilized for the entire technical area. Under the floor of the CBN Production Center, Mr. Horstmann notes, is 2200 miles of cable.

One of the inside compartments serves as the audio duplicating facility which supplies audio tapes of the "700 Club" program to more than 120 radio stations.

Videocassette Duplication

An adjoining space is the videocassette duplicating facility which includes sixteen 3/4-inch machines. Cassettes are supplied to cable systems as well as the

Armed Forces Radio-Television Network and other subscribers. A small editing suite in the Technical Operations area is used for editing tapes from field remotes. Two of CBN's four TK-760 cameras, along with the two TK-76's are largely used for field production work, with excellent results. Recording is handled by a Sony 4800. The 3/4-inch tapes are up-dubbed to 1-inch during the editing process.

Quad VTR's Keep Rolling Tape

Eight RCA quad tape machines are lined up in a row—four TR-70C and four TR-600A. As noted previously, this arrangement permits using the rear of the machines as divider wall, with ready access for service.

According to Jerry Horstmann, these quad machines operate 24 hours a day, mostly for dubbing. Their reliability has been excellent, he says. Each machine is removed from service one day each month for maintenance. The four TR-600A VTR's are interfaced with the CMX-340 editing system for those clients who prefer editing with quad.

Quad tapes are supplied to 79 U. S. television stations and to overseas broadcasters.

A TCR-100A "cart" machine is used as a video source in production for inserting

promos, ID's and PSA's.

19 One-Inch VTR's

Also in the Technical Operating Area are nineteen one-inch VTR's which are arranged in groupings of two and three machines in booths, for production editing. The booths are glassed in and are aesthetically arranged to provide full visibility for four groups visiting CBN headquarters.

Each control room is normally assigned five 1-inch VTR's for production; two editing suites have three each, and two are used for satellite air feed.

All tape librarying at CBN is now done in the 1-inch Type C format. In addition, all quad tapes in file have been dubbed to 1-inch. This has produced a saving of \$800,000 in tape cost and has provided a large inventory of quad tape for current and future program dubs, Mr. Horstmann says.

Two Editing Suites On-Line

Two CMX-340-equipped editing suites are a part of the Technical Operations area, operating a full six-day, 90 hour-a-week production schedule. Both suites have a normal complement of three 1-inch VTR's—two play and one record—but for special requirements, the two suites' machines can be cascaded together for a five playback capability.



Videocassette duplicating facility in Technical area.

Extensive video tape operation includes both quad and one-inch VTR's.

CBN's attractively landscaped grounds provide a convenient setting for an outdoor production using a TK-76 camera.

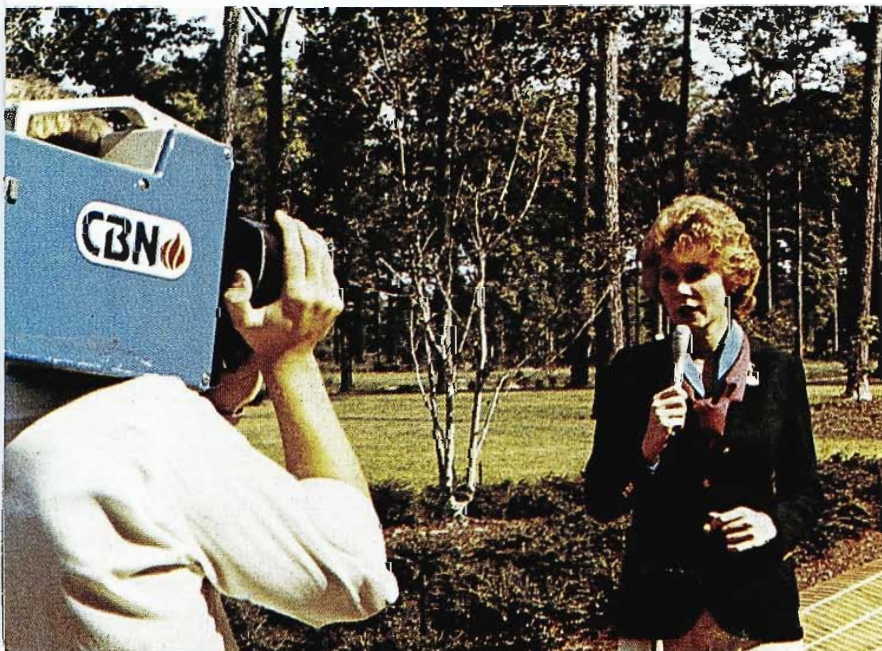

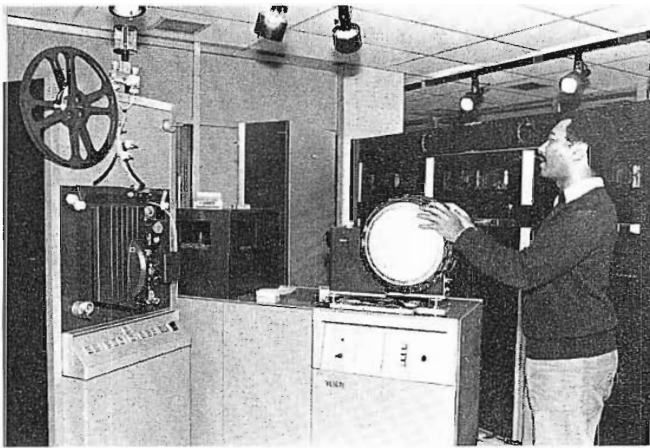

One of two telecine systems in the Technical area (top).

Program Continuity Control handles program distribution via satellite for all U. S. time zones.



Each pair of production machines can be used for frame-accurate butt edits, and one pair is equipped with an ECS-102 editor with cut-lap and lip-lock features. A full capability ¾-inch off-line suite will be available in the near future with CMX-compatible decision listing.

Program Continuity Control

Two TK-27 telecine islands in one corner of Technical Operations handle film and slide requirements. Another corner houses the PCC Room (Program Continuity Control). This compact one-man operation controls program distribution via satellite for all U. S. time zones, 24-hours-a-day. Plans call for adding a second PCC room so that one will handle transmissions for the Eastern and Central time zones; the other Mountain and Pacific zones.

Engineering and Maintenance Area

Engineering and Maintenance occupies a large area separate from the Technical Operations Center. This space includes:

- Terminal racks for audio and video distribution systems
- Patch panels (as a back-up for the computerized system)
- Set-Up Terminals (SUT) for TK-47 Automatic Cameras
- Shop-Repair Area
- Parts Storage and Inventory Control

Customized Routing System

All house signals come through the master video and audio routing system racks which are located in the Engineering and Maintenance area—and are routed from there.

The routing system is another example of the long-range planning that typifies the CBN technical operation. The customized system has 100 × 100 cross-points and can be expanded to a 240 × 240 system, according to Mr. Tolbert. The system is designed to handle up to 100 video tape machines. (The CBN Center now includes 19 1-inch VTR's; 8 quads and 21 ¾-inch videocassette units.)

TK-47 Set-Up Terminals

The TK-47 Set-Up Terminals are infrequently used, since the day-to-day operational checks are routinely made from the camera remote control units which are located in each of the two main production control rooms.

Parts Storage and Inventory Control is a function of Engineering and Maintenance which also has been computerized for efficiency and cost effectiveness.

Excellent Utilization of Computer-Based Systems

Considering the background of Director of Engineering Sam Tolbert, there is little wonder that computers play a large role in the CBN technical operation. Mr. Tolbert came to CBN nine years ago, with a communications background, with previous work experience involving deep space projects and the Apollo missions.

CBN Technical Operations utilizes an Alpha-Micro computer with an added disc providing the extended capability needed for various computer-based functions. The computer system is used for:

- Machine Control
- Parts Inventory
- Tape Inventory Control
- Satellite Transmissions
- Personnel Schedule Coordination

This is a multi-task system, with 15 terminals at various locations in the Center.

Computerized Machine Control System

As noted in the *Production Control* text, the computerized Machine Control system at CBN permits accessing all video and film machines from keyboard/display monitors. This system was developed by Staff Engineer Gene Starr to solve a problem. The 1600-7K Production Video Switcher accommodates 25 inputs—far fewer than the 80 required by CBN. The solution was a computerized machine control system that utilizes the last three buttons on the switcher (designated "A"; "B"; "C") as inputs from two 40-input routing switchers. This system provides 80 inputs and 12 outputs.

Further, the system provides production flexibility by making "Roll" controls for all video tape and film machines available in each Production Control room. The system operates on RS-232, with two twisted pair wires interconnecting machines in the system via an interface panel at each connected machine.

Using a keyboard, an operator can call up a status display of all machines in the system, showing which are in use, by whom, and what the priority status is of each machine in use. Each machine is assigned a number. While some VTR's are delegated to specific functions—Production Control rooms; Editing Suites; Dubbing—the delegation is not exclusive, and any of them can be accessed through the Machine Control System. (Obviously a machine assigned to an on-air production has Priority 1 and is locked out from other use.)

Multi-Function Cataloging System

The Parts Inventory system is one element in a fully computerized cataloging system which involves all of CBN's technical facilities. All items in the technical system—wiring, parts, modules, equipment units—are identified by number, with the data stored in the computer. CBN maintains a parts inventory in excess of \$500,000, and the computerized system permits centralizing the location of parts at the CBN Production Center, eliminating the need for duplication of parts stocking by the individual CBN network TV and radio stations. The system can be used to generate system wiring diagrams to facilitate making wiring changes when re-arranging equipment locations, for example.

Other Computer-Controlled Systems

Tape Inventory Control is also effectively handled through a computer-based system which maintains a constant status of the video tapes that are being bicycled to television stations and cable systems. All "In-Out" transactions are recorded and stored in memory.

Another computer-controlled function at CBN is Satellite Transmissions, which are scheduled and logged via a computerized system.

Still to be implemented is using the computer for personnel schedule coordination. This function will be critical as CBN expands into its projected schedule of soap operas, game shows, cartoons and other Christian-oriented program production.

Satellite Transmission Around-The-Clock
The RCA Satcom 1 communications satellite is an integral part of CBN's program distribution. The satellite is in use 24 hours a day, relaying pictures and sound signals from the large earth dish antenna on the Center site to more than 1200 receiving dishes scattered across the continent. A second dish at the Center is aimed at the Western Union Westar satellite for use as needed to link up with additional earth stations. Each antenna is equipped for both transmitting and receiving. With appropriate interconnections on the ground, the two dishes give CBN the capability of delivering live broadcasts to almost anywhere on earth.

The system is sophisticated and flexible, Mr. Tolbert explains. The two large dishes at the Center can be used for either transmitting or receiving. There are three uplinks and eight downlink receivers, permitting the simultaneous transmitting of three programs and reception of eight incoming satellite signals.

Faith Television Continues To Make Its Mark

RCA BROADCAST NEWS (Vol. #152) featured an article on Christian Broadcasting Network which tracked CBN's

growth and depicted its bustling production facility at Portsmouth, VA. The title of that article—"Faith Television Makes Its Mark"—is perhaps even more appropriate today as the new CBN Center combines expanded quality programming, a technologically advanced production facility and satellite transmission to fulfill its mission. □

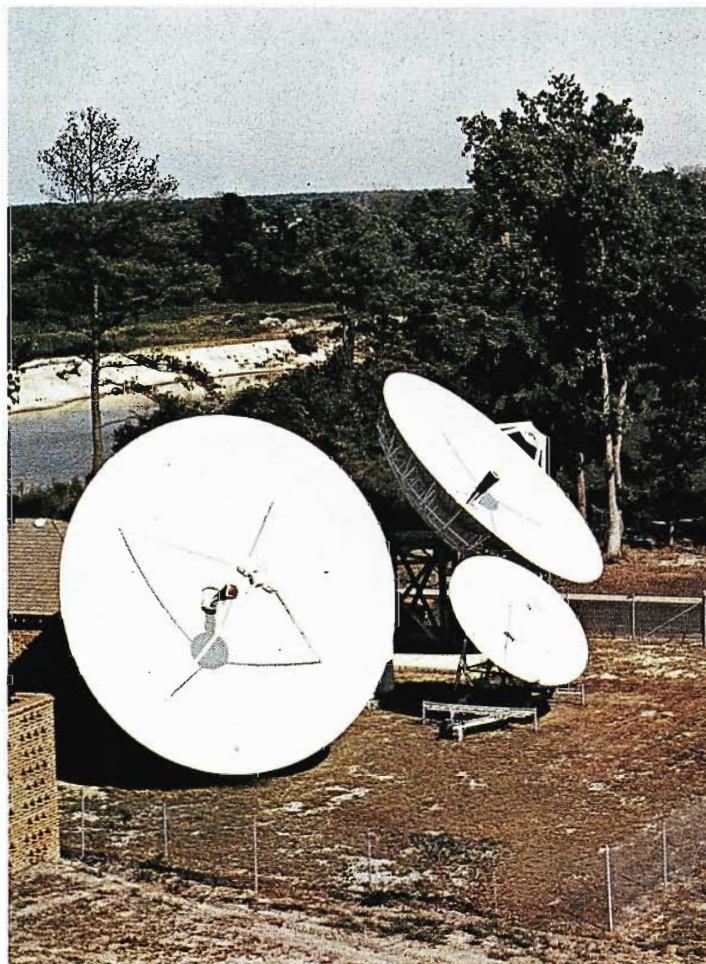
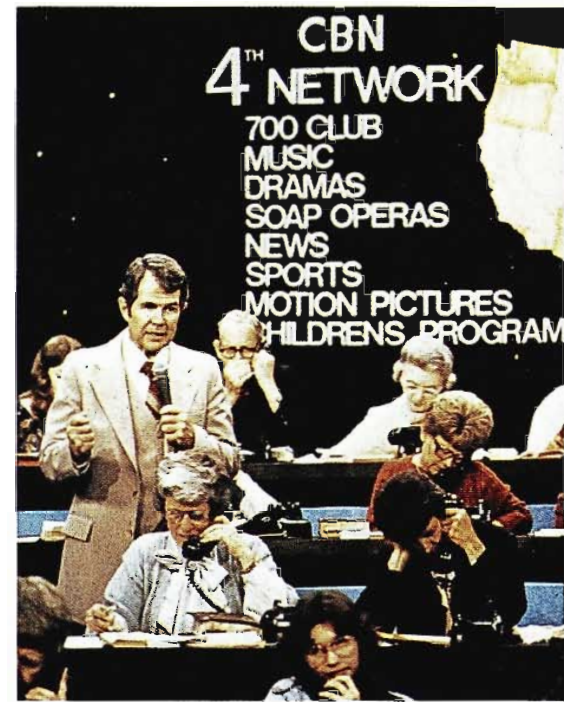

CBN's sophisticated satellite communications system has three uplinks and eight downlink receivers, permitting simultaneous transmission of three programs and reception of eight incoming signals.



RCA's TR-800 Helical VTR: a Computer- Based Total System Design

Lee V. Hedlund
Manager, Electronic Recording Equipment Engineering
RCA Broadcast Systems

Engineers assigned to the new RCA TR-800 Video Tape Recorder design project were presented with a cornucopia of opportunities and challenges.

With several Type C Format VTR's already on the market, any new tape recorder developed must include innovative features and expanded capabilities which would make it a strong contender in a very competitive market.

Technical performance specifications for the new VTR had to be superior. Ease of operation and serviceability were key considerations. And, versatility became a prime factor in the design process: The new VTR had to include a range of built-in features to fit many application needs. Further, for extended operational sophistication and flexibility, a full complement of system accessory equipment had to be developed concurrently.

Design Objectives

With these and numerous other user-needs identified, our design goal became apparent. Simply stated, this goal was to design a complete helical scan VTR system in the Type C format that would meet the needs of the discriminating user for high quality, high performance and operational flexibility in a variety of package configurations. Among the desired objectives were: improved editing capability; effective control of the variable play speed of the VTR by the editing system; expanded monitoring of the picture, waveform and audio; more remote control capability; improved reliability, and a significant reduction of non-productive editing time which could be attributed to the VTR.

To meet this formidable challenge in a reasonable time, we had to rethink the classical methods used in the design of our previous video tape recorders. We

preserved those that had served us well, and also adopted promising new techniques as necessary to produce a technologically advanced VTR.

A Micro-Processor-Based System

One of the time-tested designs that has given excellent service is the first micro-processor-based editing system for quadruplex VTR's—the AE-600 time code editing system. We chose to build on this approach in the design of the TR-800, taking maximum advantage of the innovative and highly flexible technology of the microprocessor.

In the TR-800 system, several micro-processors comprise a distributed processor system, with the main functions of the VTR being handled by a "Central processor", while individual processors manage other functions such as variable speed broadcastable picture control, time code generation and reading, and sophisticated editing.

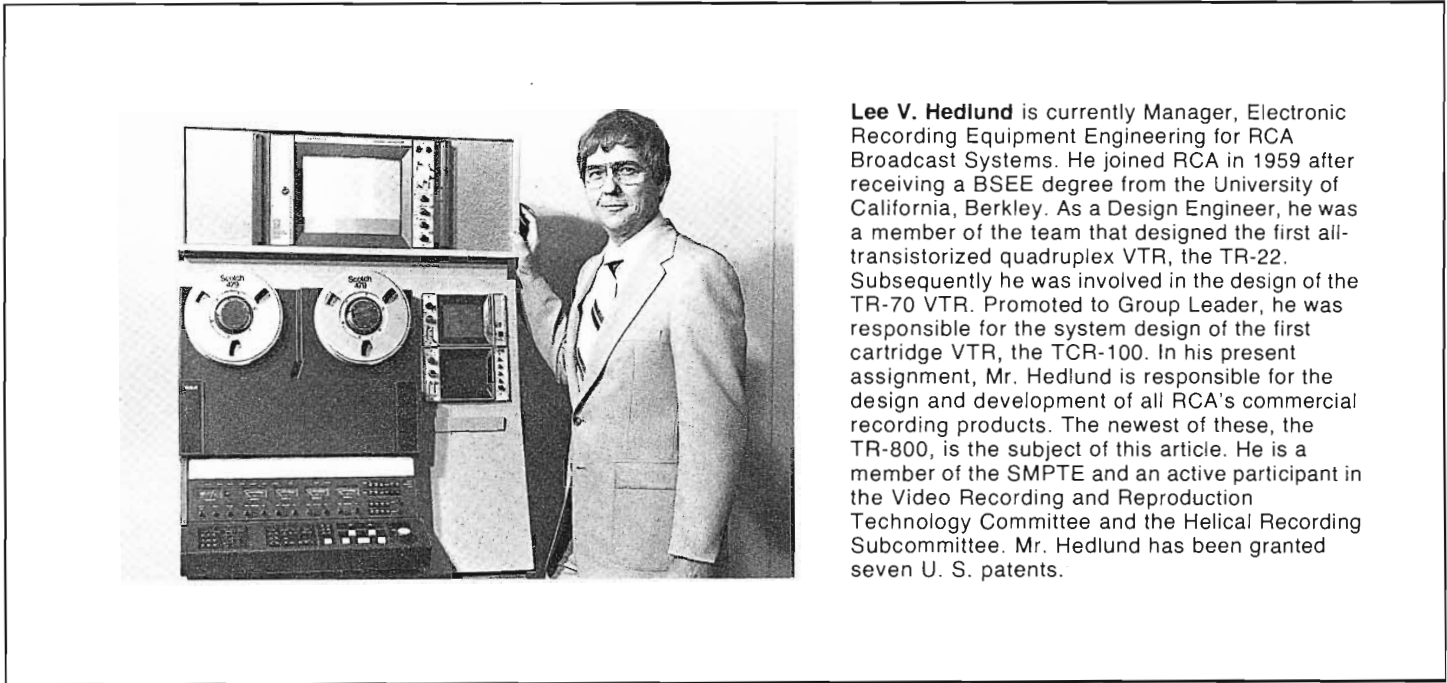

Lee V. Hedlund is currently Manager, Electronic Recording Equipment Engineering for RCA Broadcast Systems. He joined RCA in 1959 after receiving a BSEE degree from the University of California, Berkley. As a Design Engineer, he was a member of the team that designed the first all-transistorized quadruplex VTR, the TR-22. Subsequently he was involved in the design of the TR-70 VTR. Promoted to Group Leader, he was responsible for the system design of the first cartridge VTR, the TCR-100. In his present assignment, Mr. Hedlund is responsible for the design and development of all RCA's commercial recording products. The newest of these, the TR-800, is the subject of this article. He is a member of the SMPTE and an active participant in the Video Recording and Reproduction Technology Committee and the Helical Recording Subcommittee. Mr. Hedlund has been granted seven U. S. patents.

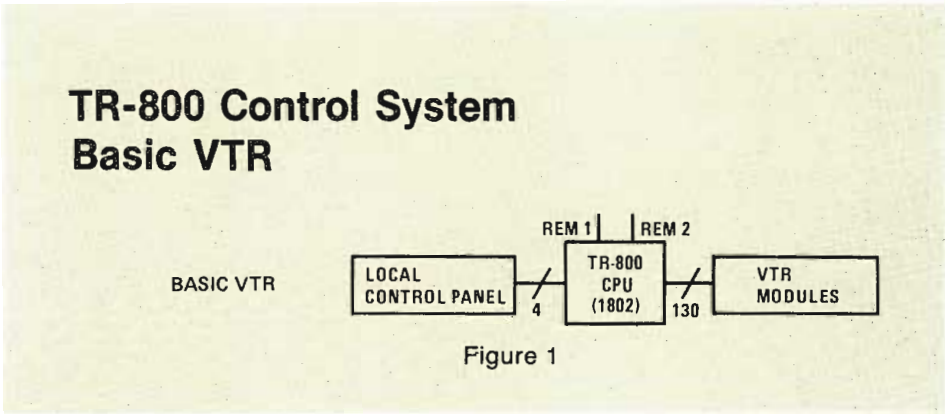

Distributed Processing

A distributed processing system utilizes a multiplicity of microprocessors, each a complete computer with a specific set of tasks to do.

Further, the system consists of a bus structure which connects all of the processors together and allows all of the processors to communicate with one another. The bus structure is generally divided into two fundamental groups called the Address bus and the Data bus. The type of device used at each processor doesn't really matter as long as a common Protocol is obeyed for communication over the bus structure. Finally, one processor is designated the "master" CPU, with the primary responsibility of keeping order among the "slave" CPU's, and of course within itself.

Central Processing Unit

In the TR-800 design, the central processing unit is located in the main module nest of the VTR. Most of the feature expansion capability of our system is provided for through the use of distributed processing. The CPU is an RCA Cosmac, CDP-1802 and the software program is stored in 4K x 8 EPROM's. The CPU is assigned the responsibility

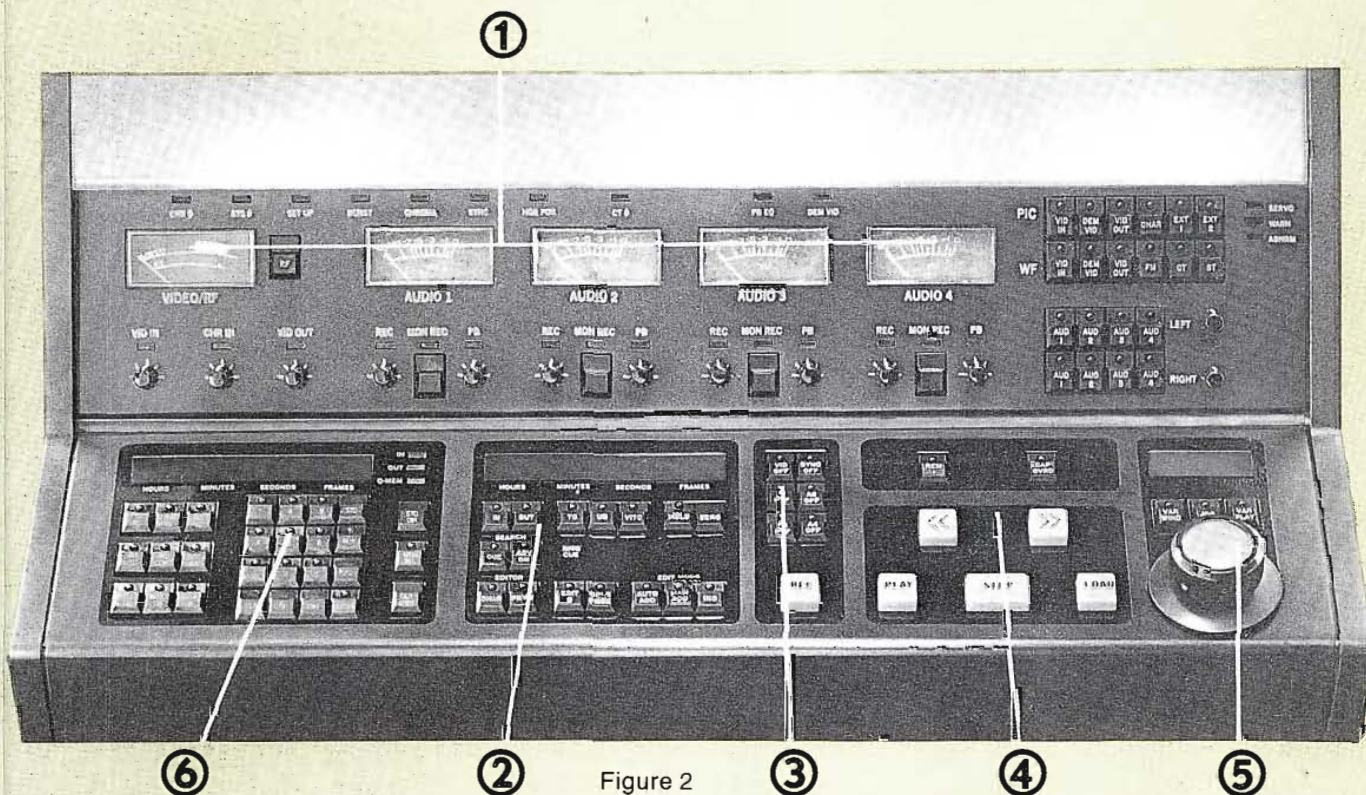

Figure 2

for handling the primary VTR interface with the operator; i.e. the main control panel and for control of the VTR itself (Fig. 1).

In its basic form, the Control Panel is partitioned into five major operational areas: (1) Video/Audio Monitoring; (2) Timer/Simple Editor Control; (3) Record Control; (4) Transport Control, and (5) Variable Speed Control. In the panel illustrated here (Fig. 2), Optional Time Code Generator and Super Search Editor controls have been added on the left (6).

In this configuration, there are 95 pushbutton switches, 114 LED or lamp indicators and 18 seven segment displays. Two standard ASCII keyboard encoders are used to encode the pushbutton data which is ultimately transmitted to the CPU. Illumination of the various LED's and seven segment displays is also controlled by the CPU via a RAM system located in the panel. The communication of the pushbutton and indicator data between the control panel and the CPU occurs at 2400 Baud over two twisted pair with a universal asynchronous receiver/transmitter, known as a UART, at each end. These are available as large scale integrated circuits (LSI) and the 40 pin RCA CDP-1854 is used in the TR-800 system.

The main software program includes a built-in basic Editor. The Tape Time of the Edit In and Out points can be stored either on the fly or in still scan. The Edit can also be previewed before it is made.

The second level of Editing, called the Super Search Editor, is available as an accessory. It is implemented by adding more software to the memory of the CPU via additional EPROM's and by adding a keyboard and overlay to the VTR control panel. The SSE is programmed to edit to either Tape Time or Time Code. The Edit In and Out points can be entered as described above for the basic Editor or they can be keyed in via the keyboard and transferred to the In and Out memories. We have also programmed the SSE to store up to nine cue points which can be used for either the Search-to-Cue function or as a temporary memory for future Edit points.

Remote Control Provisions

Remote control capability of the TR-800 is available in three forms: Remote 1, Remote 2, and Edit. The CPU memory is programmed to accommodate each of these modes.

Remote 1 employs a simple remote panel containing 5 pushbutton-indicators for the Stop, Play, Record, Wind and Rewind modes of the VTR. Delegation to this panel is via the Remote 1 pushbutton on the main control panel.

It should be noted here that neither an ASCII keyboard encoder or a full micro-processor is needed at the remote location just to get the VTR to listen and respond to five simple commands. All five functions are obtained by simple contact closures via a 24 wire cable connected to the Remote 1 I/O at the rear of the VTR (Fig. 3).

TR-800 Control System with Remote Accessories

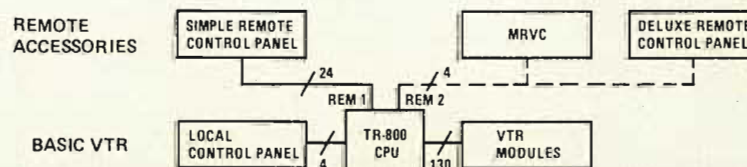

Figure 3

Remote 2 is the full VTR mode remote, and involves the first phase of our Distributed Processing system. This is a two twisted pair I/O port with delegation selected via the Remote 2 pushbutton under the flip up cover at the top of Figure 2. Two uses of this port are for either a deluxe Remote Control Panel, or for a major tape system accessory unit which we have designated as MRVC (Multi-Rate Video Controller).

The Edit mode remote provides for complete Time Code Edit control.

Major System Components

While the main thrust of this article is on the application of micro-computers to the design of the TR-800, several other key elements of the total video tape system need to be introduced. These items, which are the keys to executing the many VTR-related tasks that can be accomplished with the amazing flexibility of micro-processor technology, include:

- Tape Reeling Servo
- Capstan Servo
- Super Track Servo
- Digital Time Base Corrector
- Multi-Rate Video Controller*
- Time Code Accessory Modules*
- AE-800 Time Code Editing Systems*

The last items (identified by asterisks) utilize individual microprocessors as part of the TR-800 distributed processor system.

Tape Reeling Servo

The TR-800 incorporates a sophisticated tape tension and tape velocity servo system. The Tape Reeling Servo is depicted here in a simplified block diagram (Fig. 4). The mode and speed commands come from the CPU. In the shuttle mode, the tape tension is measured by two tension arms and the velocity is measured by a tachometer engaged with the tape. Control of these parameters is through DC amplifiers driving permanent magnet DC motors used for the supply and take up drive elements. In the Record, Play and Variable Play modes, the tension is measured and controlled as in the shuttle mode, but the tape velocity is controlled by the capstan.

The system has two tachometers; one at each end of the tape path, and the CPU selects the one nearest the reel taking up the tape. Since take up tension is precisely servo-controlled, the stretch in the tape at the utilized tachometer is the same regardless of winding in the forward or reverse direction. This assures that the best measurement possible is made of tape length or tape time as it is usually called. The same selected tachometer is used by the velocity section of the servo to control the speed at which the tape is transported from one reel to the other in the shuttle mode.

As shown in Fig. 4, the tachometer output is converted to a DC level that represents the velocity of the tape. This DC level is then sent to the velocity detector where the velocity error signal is developed. There are two fundamental aspects of velocity that are of interest: Steady-state velocity and rate-of-change of velocity. Rate-of-change of velocity is, of course, acceleration or deceleration. This velocity detector controls these important parameters. Whenever the CPU commands a new velocity via an 8 bit D/A converter, located the Computer module, it does so as a step function from the original to the new value. Inside the reel servo module, this signal passes through a ramping circuit that determines the rate of change of the input signal to the reference side of the velocity detector and hence the acceleration/deceleration characteristic of the tape reeling servo.

It is understood that the servo must have sufficient gain and bandwidth to follow the reference ramp. The performance figures achieved with this system in the TR-800 are acceleration/deceleration of

125 inches per second per second and a top speed of 450 inches per second or 45 times play speed. Put another way, this means that the TR-800 will accelerate from zero speed to full wind speed in under 4.0 seconds and will rewind a one hour program in under 90 seconds. It will also recue a 30 second segment in under 5.5 seconds. The recue time includes cueing to within one frame of the desired cue point.

Also included in the tape reeling servo is automatic control of the tape tension to remove skew error in playback. The primary cause of skew error is a difference in the tape tension between record and playback and this results in what is sometimes called "flagging" at the top of the picture.

The skew servo section of the reel servo corrects this error by measuring the relative timing difference between horizontal sync pulses before and after the vertical interval. If a timing error exists, an appropriate change is made in the tape tension by altering the hold-back torque of the supply motor to reduce the error to zero.

The servo system and transport have also been designed to handle the complete gamut of reel sizes, from the very small to the very large.

The system accommodates small plastic reels for commercial spots as well as a full two-hour reel which can hold a complete prime time movie or special. The two-hour reel uses standard thickness tape for optimum interchange and performance, and no component changes are needed to use this reel size.

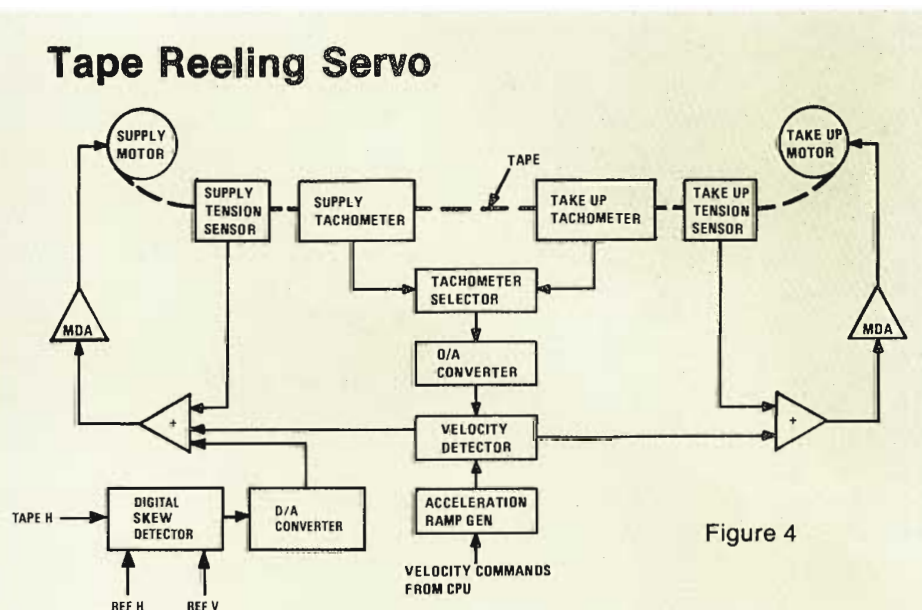

Figure 4

Capstan Servo

There is a unique feature of the Capstan Servo that makes it a key building block in the complete system approach taken in the design of the TR-800. That feature is variable speed control of the capstan in both forward and reverse directions in incremental rate differences as small as one field per second.

As shown in Fig. 5, the heart of the Capstan Servo system is the speed synthesizer which is used to control the capstan speed in the Variable Play mode. The divider in this loop determines the frequency of the VCO, which in turn determines the speed of the Capstan via the Motor Loop. The division ratio of the divider is stored as a look-up table in a PROM and is selected by the speed request command from the CPU.

By making this a digitally controlled system, the operator is offered a large choice of variable playback speeds which are repeatable. The increments of speed have been programmed in a unique fashion (Fig. 6). Note in particular the increments around normal play speed and you can see that one-field resolution is provided between 24 and 36 frames-per-second. The significance of this resolution and the capability of programming the speed will be ex-

plained later.

SuperTrack Servo

The SuperTrack accessory for the TR-800 provides for broadcastable color playback from reverse motion through still frame to fast motion. Total control of this facility is integral to the TR-800, permitting on-line control as well as pre-programming capability.

The SuperTrack Servo System (Fig. 7) is responsible for keeping the ST video playback head on the recorded track in the Play and Variable Play modes. It employs a video head mounted on a sandwiched piezoelectric structure that can be driven in a direction perpendicular to the recorded track. The well known scheme of dithering the head and measuring the FM amplitude in a synchronous detector is employed to develop the servo error signal.

The dither voltage waveform is sinusoidal and its rate is 720 Hz, which is twelve times the rate of vertical sync. As the head scans the recorded track at this frequency, maximum FM amplitude occurs from the head when the dither voltage is zero and the head is centered on the track (Fig. 8). The minimum occurs when the dither volt-

age is either minimum or maximum. The resultant amplitude modulation of the FM is at twice the dither frequency. The error signal for the servo is developed by sampling the resultant FM amplitude modulation in a synchronous detector at a frequency of 1440 Hz, which is also twice the dither frequency.

The error signal is then sent to a summing amplifier where the jump signal is an amplitude-modulated sawtooth with a period equal to the time between vertical sync pulses recovered from the demodulated video. The time of the jump is coincident with the detection of vertical sync and the amplitude of the jump is a function of linear tape speed which is measured by detecting the actual frequency of the horizontal sync recovered from the tracks being scanned.

The amplitude deflection of the head is a function of the length of: the bimorph element between the head and the surface on which the bimorph element is mounted, the deflection sensitivity of the element to the driving voltage, and the maximum driving voltage applied. Our system provides for a maximum deflection of roughly 14 mils or two tracks.

Capstan Servo

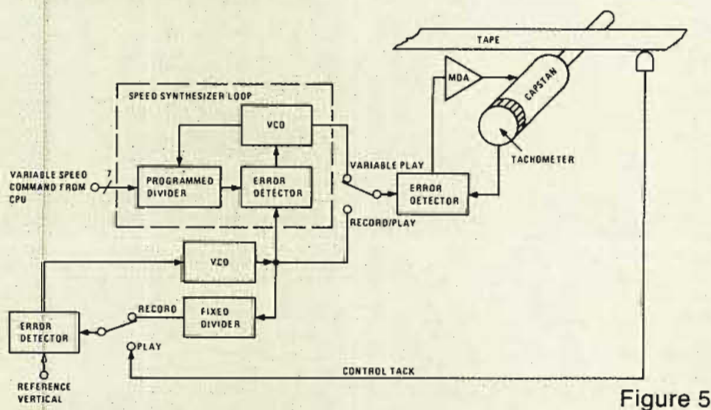

Figure 5

Super Track Servo

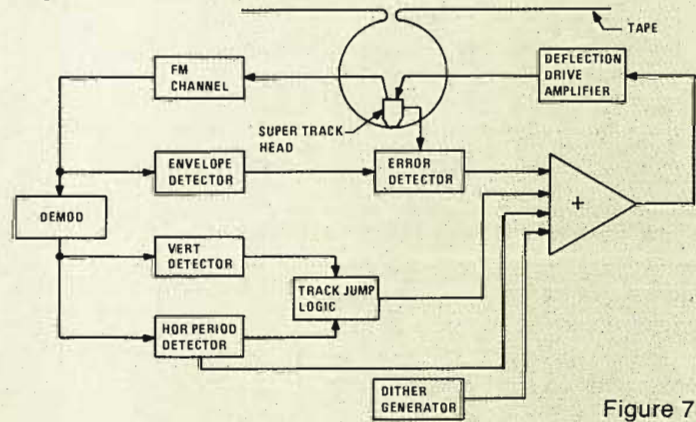

Figure 7

Capstan Variable Speeds

| | | | | | | | | | | |
|-------------------|-------|---|---|-------|----|-------|----|----|----|---|
| PLAY SPEED | -0.33 | 0 | | +1.0x | | +2.0x | | | | |
| FRAMES PER SECOND | -10 | 0 | 9 | 24 | 30 | 36 | 42 | 48 | 60 | |
| FRAME INCREMENTS | | 2 | | 1 | | 0.5 | | 1 | 2 | 3 |

Figure 6

Concept of Dither

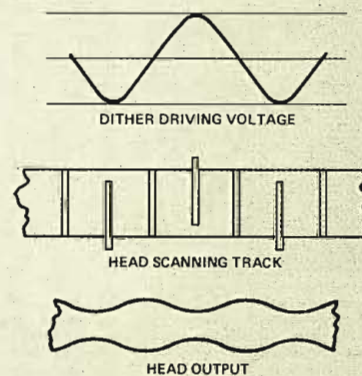

Figure 8



TBC-8000

Digital Time Base Corrector

Several unique design features make this unit more than just another Digital TBC—not the least of which is the fact that it was designed from the ground up to continue the full microcomputer-controlled system concept of the TR-800 program.

As shown in the block diagram (Fig. 9),

the TBC-8000 contains all of the usual TBC items, including DOC and VEC. However, Time Base Correctors for Type "C" helical scan VTR's need another capability—reconstruction of the NTSC four field color sequence from any one, but only one of the four fields. There are many ways to do this, but they all involve separating the chroma from the luminance and then recombining these signals in a manner to effectively

produce the NTSC four field color sequence.

In the TBC-8000, this function is performed in the digital domain for enhanced performance and long term stability. The process involves chroma inversion; hence we refer to this subsystem as the Digital Chroma Inverter (DCI). With the DCI, color rendition is possible at tape speeds up to ten times play speed.

The TBC-8000 Dropout Compensator is another unique design which is also implemented in the digital domain. The specific implementation is a technique called six point surround replacement (Fig. 10). This approach interpolates the six closest samples around the missing bit by the formula at the bottom of the diagram and uses the resultant to make the final replacement. Since this approach employs a look-ahead concept, it handles diagonals and transitions very well and produces the most ideal replacement of any system designed to date.

Another unique feature which is a significant advantage to the operator is the TBC signal remote. All of the ProcAmp controls are remoted directly to the main control panel on the TR-800. Functions remoted are: Video; Chroma; Pedestal; Burst and Sync levels; Chroma and System Phase and Horizontal Position.

The memory architecture in the TBC-8000 is arranged for simple expansion of the memory. It allows for the most simple version of the TBC to contain as little as 6H of memory, which results in a 4H correction window. Other versions are possible all the way to 24H of memory in increments of 6H. The memory structure requires only 2H of overhead to prevent collision of the read and write functions and the overhead remains constant regardless of total memory size. Therefore, the correction-window possibilities are 4, 10, 16 and 22H. The 10H version is standard in the TBC-8000.

One more important point about the memory structure: neither the DOC nor the DCI consume any of the main correction memory. This means that the main memory really produces the amount of correction range specified and that the DOC and DCI performance remain constant up to the last line of memory consumed for actual time base correction.

Digital Time Base Corrector

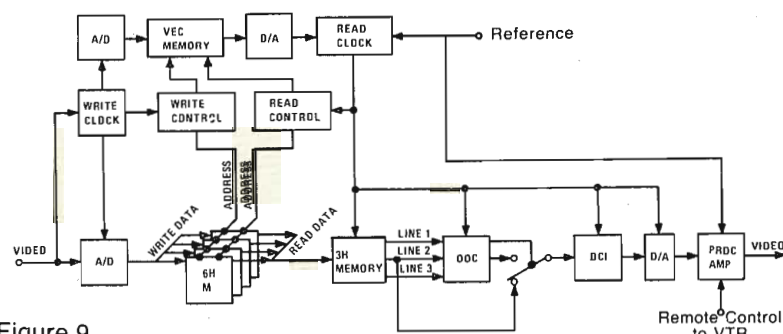

Figure 9

Six Point Surround DOC

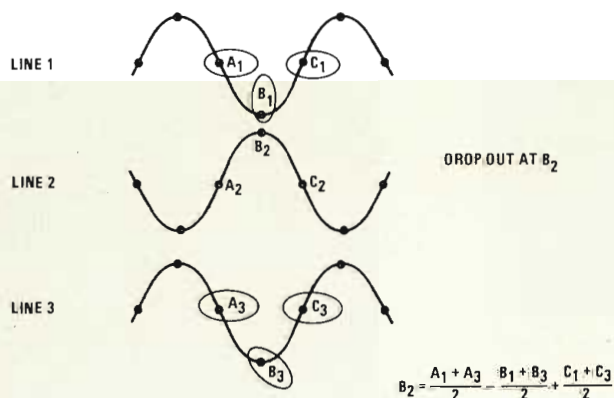

Figure 10

$$B_2 = \frac{A_1 + A_3}{2} - \frac{B_1 + B_3}{2} + \frac{C_1 + C_3}{2}$$



Multi-Rate Video Controller (MRVC)

Multi-Rate Video Controller

With the MRVC, variable speed replays in forward or reverse are easily handled by the TR-800. This facility handles instant replays and slow motion operations in sports, and is useful in production for special effects and time compression or expansion.

The Multi-Rate Video Controller measures 11.5 inches wide, by 14.5 inches deep, by 9 inches high and weighs approximately 15 pounds. It contains another CDP-1802 Microprocessor with about 12K of software and a power sup-

ply, making it a completely self contained microcomputer. Communication with the TR-800 CPU is over two twisted pair via the Remote 2 I/O and a CDP-1854 UART at each end. With the MRVC, the VTR operator can store up to 12 cue points during each recording. The record time and cue points are displayed on two linear bar graphs to depict relative time. The bar graph is designed to display either 60 seconds or 6 minutes of elapsed record time. Selection of the desired time display is by a range switch to the left of the displays.

Program Time Alteration

$$\text{TAPE LENGTH} = \text{RATE} \times \text{TIME}$$

$$L = RT$$

ORIGINAL TIME

$$L_1 = \text{TAPE LENGTH TO BE PLAYED}$$

$$R_1 = 30 \text{ FRAMES PER SECOND NORMAL PLAY SPEED}$$

$$T_1 = 32 \text{ SECOND PROGRAM SEGMENT}$$

NEW TIME

$$L_2 = \text{TAPE LENGTH TO BE PLAYED}$$

$$R_2 = \text{NEW PLAY SPEED}$$

$$T_2 = 30 \text{ SECOND PROGRAM SLOT AVAILABLE}$$

$$L_2 = L_1$$

$$R_2 T_2 = R_1 T_1$$

$$\boxed{R_2} = \frac{R_1 T_1}{T_2} = \frac{(30 \text{ f/s}) (32\text{s})}{(30\text{s})} = \boxed{32 \text{ FRAMES PER SECOND}}$$

Figure 11

The MRVC also allows the operator to command the TR-800 to return to the beginning of the recording with the push of only one button. Other cue points can also be easily selected. The MRVC will also control the TR-800 in the Play or Variable Play modes. The operator can select any of the preset playback speeds using one pushbutton, or control the VTR over its entire range of playback speeds by means of a linear slider mechanism. A "Time Remaining" display provides a constant update of time to the end of the recorded section regardless of speed selected during playback.

Putting It Together

Before proceeding, let's re-cap briefly a few important TR-800 system components that have been covered so far: A Distributed Processing System; Multi-Rate Video Controller; a tension-and-velocity-controlled tape reeling servo; a wide range variable speed controlled capstan; a SuperTrack video head deflection servo, and a wide range Digital TBC.

By putting all of these elements together, we have broadcastable color pictures from $-\frac{1}{3} \times$ to $+2.0 \times$ play speed which are all programmable via the CPU in incremental rates as small as one field per second. Not only will the system do the standard tasks of an instant replay device for sports, but it will do some special tricks such as time compression and time expansion of program material.

Take, for instance, this application. You have a 32 second program that you want to edit into a tape or dub for later play to air. There is only one hitch. The final time slot available is only 30 seconds. Solution: Dial 32 into the variable play speed control of the TR-800. In this mode, that number represents 32 Frames per second and the 32 second tape will be played in 30 seconds as shown by the calculation in Fig. 11.

Not only could this save a lot of time for people who may have had to do some fancy editing of the video, but the same advantages may accrue with the audio.

If the magnitude of the time change is small, the resulting pitch change in the audio may not be objectional and it would be possible to dub the time-altered audio at the same time as the video.

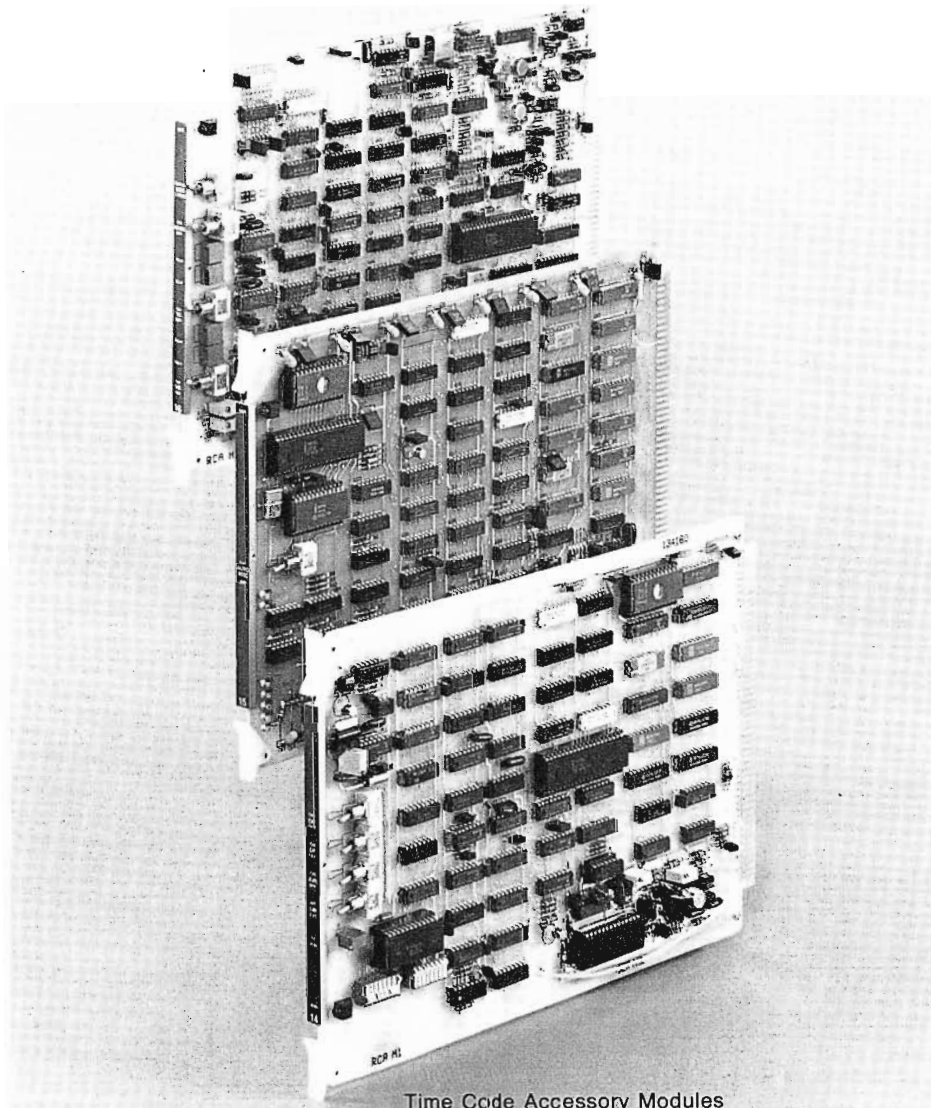

Time Code Accessory Modules

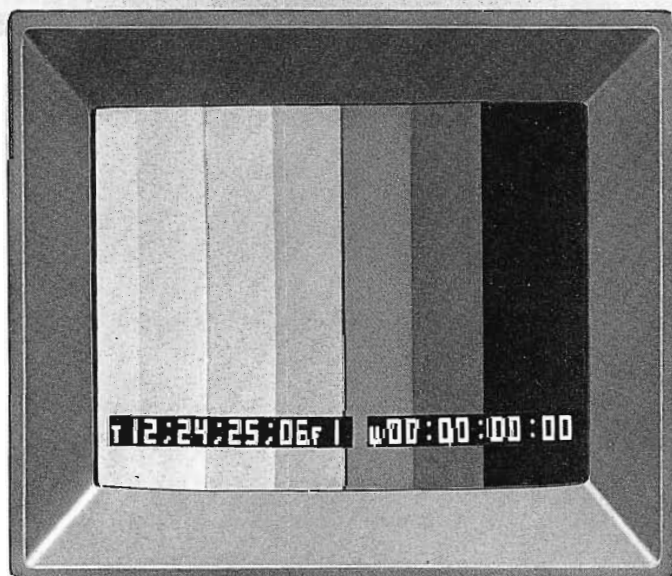

Time Code Accessory Modules

Thus far, only the basic editing facilities of the TR-800 have been mentioned. Now we are about to return to the world of microcomputers and a description of their function in the sophisticated Time Code Editing capability developed for this new VTR.

The three accessory Time Code modules for the TR-800—Time Code Generator; longitudinal Time Code Reader, and the Video Time Code Processor—are all housed in the main module nest of the VTR. Each of these modules includes a full microcomputer as part of the TR-800 Distributed Processing system.

The TR-800 CPU communicates with these modules over the TR Bus and requests a specific module to process a particular function (Fig. 12). The responsible processor performs its task and when finished, communicates an appropriate status back to the CPU.

An 8035 microprocessor is used in all three modules since it is smaller than either the 1802 or 8085 and also contains an internal RAM. This is an important consideration in minimizing the use of valuable space in the VTR. This factor, together with the fact that we have used a microprocessor for each module function, allowed us to get all of these functions on just three modules.

Fig. 13 is a simplified block diagram of the Time Code Generator module. Other than the fact that a microprocessor is used as part of a Distributed Processor system, the important thing to note is

TR-800 Control System Time Code Accessories

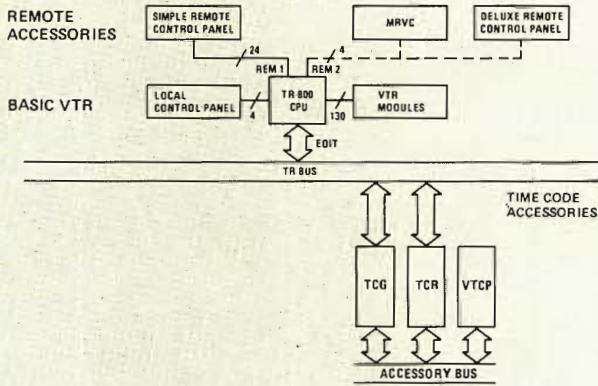

Figure 12

Time Code Generator

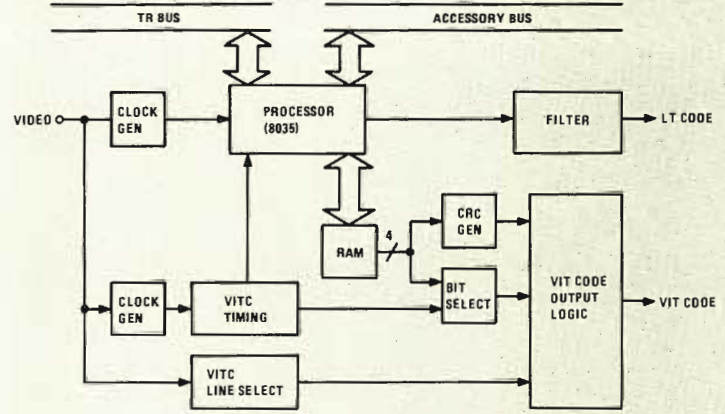

Figure 13

Time Code Reader

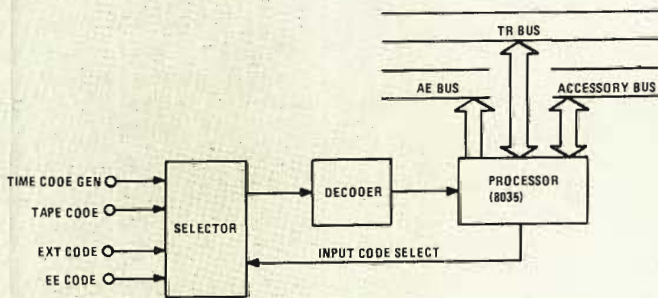

Figure 14

Video Time Code Processor

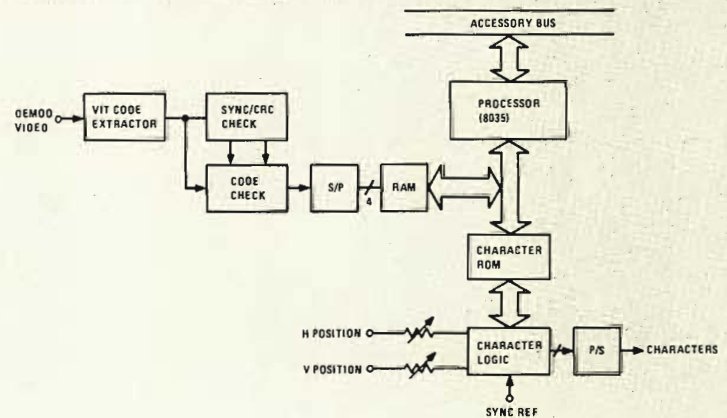

Figure 15

that this TC Generator is designed to provide Vertical Interval Time Code in addition to the standard longitudinal SMPTE Time Code.

VIT Code consists of two identical blocks which can be located on any two non-adjacent lines starting from line 10 and ending on line 22 of the vertical interval of every field. Included in each block of 90 bits are 18 sync bits distributed through the code, 64 data bits and finally 8 bits for a CRC code. It is the two identical non-adjacent blocks plus the CRC code that provides redundancy to insure adequate decoding accuracy.

The main task of the second Time Code accessory module, the Time Code Reader (Fig. 14), is to read the longitudinal code (LT Code). Its secondary task is to

pass on the VIT Code obtained from the third module to the TR-800 and the editing system at the appropriate time. The front end of this module is a proven design which has served us well in the AE-600 editing system. As in all such systems, it does, however, have a lower limit in tape speed at which it will no longer read the longitudinal code successfully. This is where VIT Code comes in again and leads us to the third and final Time Code Accessory module.

In addition to extracting the VIT Code from the video signal, the Video Time Code Processor module (Fig. 15) has two other major functions to perform. The first function is to decode the VIT Code and send the data over the Accessory I/O Bus to the Time Code Reader module where it is automatically or

manually selected and sent on for display on the various seven segment displays of the system. The automatic selection of VIT Code occurs at speeds below which the LT Code can be successfully read. The second function is to format the two codes for display on a standard TV monitor. The characters are white and are inserted into the video either with or without a black surrounding box, depending on the choice of the user. The character height and position is also variable. A choice of either 28 or 42 raster line high characters is provided and they can be positioned anywhere on the raster. Although the three accessory modules are totally self sufficient when housed in the TR-800 main frame, there is a further use for them—operation with a full Time Code Editing system.



Local Control Panel for AE-800 Time Code Editing System

AE-800 Time Code Editing System

The final and most significant element of the TR-800's Distributed Processing System is the AE-800 Time Code Editing System. The expanded Distributed Processing System depicted in Fig. 16 shows the impact of the complete system.

An 8085 in the AE-800 communicates with the CPU in the TR-800 over the TR Bus via Edit I/O port, the last of our remote ports. It also communicates with the three Time Code accessory modules through the Time Code accessory Generator modules and the Accessory Bus. The TR-800 CPU independently communicates with these modules over the TR Bus. In addition, another 8085 is housed in the CRT/Printer interface to allow timely display of Edit decision data on the CRT built into the TR-800 studio console and for logging the desired data on any standard hard copy printer. Operator control of the AE-800 is through either the local control panel for simple standup style editing or from the AE-800 remote control panel for more sophisticated three machine editing. The final microprocessor of our system, an 8085, is located in the AE-800 remote control panel.

A major feature we have included in the design of this editing system is complete control of the Variable Play mode of our VTR. This means that an operator can request a particular play speed from the source machine to fill an available time slot in a master tape on the record machine. The system will calculate the required cue point for the source machine, based upon its play speed, and automatically cue the VTR to this point.

Summary

In this article, no attempt has been made to cover the total design of the TR-800 VTR in any detail. There has been no discussion of the design as it relates to picture, waveform and monitor selection; beginning and end-of-tape sensing and warning indicators and so on. And the AE-800 editing system was touched on only briefly in terms of its utilization of microcomputers and not at all in terms of its extensive editing capability and flexibility.

As noted earlier, the main thrust of this article has been to describe the use of microprocessors in designing the TR-800 and its system accessories. Fig. 17

TR-800 Control System Full Distributed Processing System

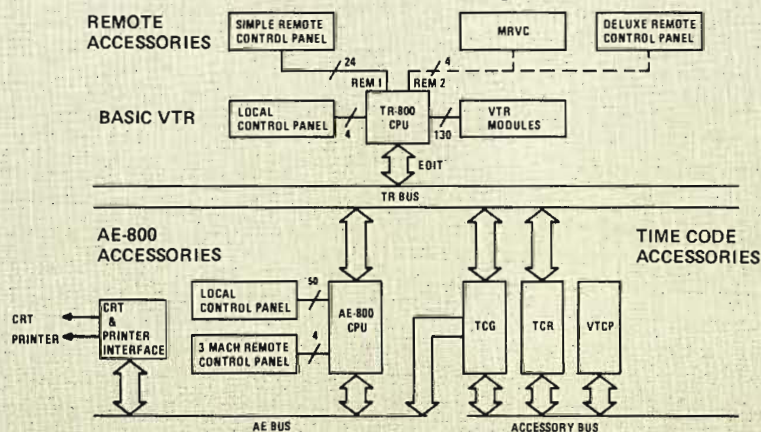

Figure 16

Microprocessor Summary TR-800 System

| <u>LOCATION</u> | <u>CPU TYPE</u> | <u>PROGRAM SIZE</u> |
|-----------------------------|-----------------|---------------------|
| TR-800 CPU | 1802 | 30K |
| MULTI-RATE VIDEO CONTROLLER | 1802 | 12K |
| ACCESSORY MODULES | | |
| TIME CODE GENERATOR | 8035 | 2K |
| TIME CODE READER | 8035 | 2K |
| VIDEO TIME CODE PROCESSOR | 8035 | 2K |
| AE-800 CPU | 8085 | 20K |
| CRT/PRINTER INTERFACE | 8085 | 5K |
| REMOTE CONTROL PANEL | 8085 | 5K |
| TOTAL PROGRAM | | 78K |

Figure 17

summarizes the complement of microprocessors in the TR-800 system and their primary tasks, with an indication of the program size for each. The full system contains eight individual microprocessors and a total of about 78K of program. Consider, if you will, the significance of this for a moment or two.

The use of microprocessor technology has allowed us to pack a host of valuable features and performance in a very compact package. If we were to implement this design in hardware without microprocessors, the complete distributed processing control system alone would occupy the space equivalent of two and one half control systems of a TCR-100 Video Cart machine, or of ten IDA/ADA Video Cassette identification systems, or of the control system of ten basic Quad VTR's.

There is no question that the microprocessor will have a significant impact in the 1980's on the people who make and use broadcast quality equipment. It already has. In fact, the TR-800 system could easily be called the first digital VTR of the 1980's. □



THE GROWING POPULARITY OF RCA CIRCULARLY-POLARIZED ANTENNAS FOR TELEVISION: A SUCCESS STORY.

When first introduced a few years ago, circular polarization for TV was a promising new technology, ready to go, but waiting for broadcast industry response.

Early evaluations of the new CP operation on-air confirmed its anticipated advantages—particularly in improved coverage and reception—and product development moved forward.

RCA's Antenna Engineering and Manufacturing facility in Gibbsboro, New Jersey, utilized its resources and expertise in antenna design to develop a family of new CP antennas for both VHF and UHF broadcasters. Four CP antennas are available for highband and lowband VHF stations, for top and side-mount, including two models that can be direct replacements for existing Superturnstile antennas. The UHF model is designed for direct mechanical replacement for most of RCA's horizontally polarized Pylon antennas.

With the increased availability of circularly polarized antennas and encouraging reports from early users, broadcasters have responded with new orders that are building at an accelerating rate. Listed here are the stations already on air with RCA CP Antennas and those with antennas either under construction at Gibbsboro, or shipped, but not yet on-air.

RCA's Circularly Polarized Antennas On Air

| | |
|-------------------------------------|--------|
| WLS, Ch. 7, Chicago, IL | Custom |
| XETV, Ch. 6, Tijuana, MX | TFV |
| WTTV, Ch. 4, Indianapolis, IN | TFV |
| WRAL, Ch. 5, Raleigh, NC | TFV |
| WTVD, Ch. 11, Durham, NC | TCL |
| WPBT, Ch. 2, Miami, FL | TBK |
| WITN, Ch. 7, Washington, NC | TBJ |
| WFMY, Ch. 2, Greensboro, NC | TFV |
| WBTW, Ch. 13, Florence, SC | TCL |
| WVTM, Ch. 13, Birmingham, AL | TCL |
| WCTI, Ch. 12, New Bern, NC | TCL |
| WABC, Ch. 7, New York, NY | TBJ |
| WNCT, Ch. 9, Greenville, NC | TBJ |
| KCPQ, Ch. 13, Tacoma, WA | TBJ |
| TV National, Ch. 7, Santiago, Chile | TBJ |

RCA's Circularly Polarized Antennas Under Construction Or Shipped

| | |
|---|-----|
| Radio Difusor, Ch. 4, Sao Paulo, Brazil | TFV |
| KCRA, Ch. 3, Sacramento, CA | TDM |
| TV Litoral S.A., Ch. 3, Argentina | TDM |
| WBNS, Ch. 10, Columbus, OH | TCL |
| KSTW, Ch. 11, Tacoma, WA | TCL |

At RCA, the success story is in the CP antennas designed, and also in the success that users are achieving in their application. And that is a great story! Ask your RCA Representative for details, or write RCA Broadcast Systems, Bldg. 2-2, Camden, NJ 08102.



RCA Circularly Polarized Antennas

- Type TBJ—Panel, Top or Side Mount, Highband VHF
- Type TBK—Quatrefoil, Side Mount, Lowband VHF
- Type TCL—Tetra Coil, Top Mount, Highband VHF
- Type TDM—Dual Mode, Top Mount, Lowband VHF
- Type TFU-CP—UHF Pylon, Top Mount, Ch. 14-70

Be where the news is happening at NAB. Visit the RCA exhibit and try out our lightweight new TK-86. It's a worthy successor to RCA's trusty TK-76, the ENG/EFP veteran that's served beyond the call of duty on newsfronts around the world. Through hell and high water.

It has the same basic electronics as the celebrated TK-76, but uses 33% less power. And there's the same ruggedness, reliability and serviceability. But shoulder the TK-86, and feel the difference.

With its form-fitting base, it nestles comfortably and securely on the shoulder. It's nicely balanced. And it can remain conveniently upright when you set it down.

It has an improved optical system, with a totally-sealed f/1.4 beam splitter. It's available with low-capacitance versions of the Saticon® or Plumbicon® tubes. And with a full range of remote control devices.

Of course, it's backed by incomparable RCA Tech Alert

service. See it at NAB or see your RCA Representative. RCA Broadcast Systems, Building 2-2, Camden, NJ 08102

NAB NEWSMAKER

Can you really afford less?

CONTROL LIKE NEVER BEFORE.

The new RCA TR-800. It's everything you've asked for in a one-inch tape system. And more.

When you called for gentler, more precise tape handling, we were listening. When you asked for faster, easier operation and control, we heard you. And when you told us you wanted better editing capability, we took note. Our response is the new TR-800. It's the one-inch tape system you specified. In addition, we've included some years-ahead innovations of our own.



Designed for you.

Everything about TR-800 is engineered to make your job as easy as possible, from the tape-end sensing feature to the ultimate in microprocessor controls.

We've designed the tape path to give you straight-through threading. And tucked all electronics behind a drop-down panel for on-air accessibility. This panel includes all the

controls for the new digital Time Base Corrector (TBC-8000). The TR-800 is equally at home in a van, rack, T-cart or console. But the big feature is control. Unprecedented control.

New editing precision.

TR-800 lets you expand or compress materials to fill time slots with frame-by-frame, field-by-field precision.

With our Supertrack option, play back with broadcastable quality from reverse

slow motion through still scan to forward fast motion. An LED digital readout tells you the exact tape speed. Edit with the microprocessor-controlled pre-viewable editor, a standard feature. And we offer additional distributed processing through such accessories as Super Search Editor (SSE), a Multi-Rate Video Controller (MRVC), and a unique time code editing system (AE-800) that fully addresses C format capabilities.

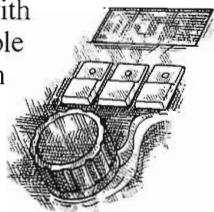

A system that does it all.

Use TR-800 as an instant replay, slo mo and freeze frame unit. Use its superb editing control for special effects and precisely programmed edits. Get full video and sync record/playback capabilities plus three audio channels. Get complete video sync and audio simulplay. Get complete video monitoring selection, metering and two built-in speakers. In post-production, the unrivaled acceleration and easy operation of TR-800 save time and money, while helping you turn out a superior product. Any way you use it, you're ahead.

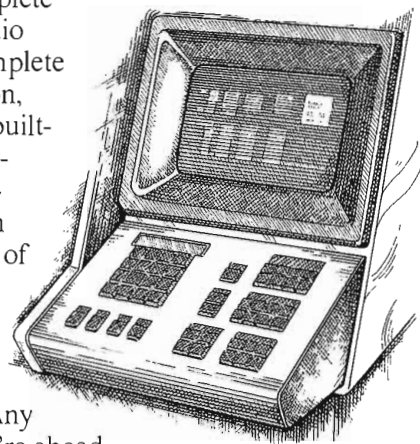

See for yourself.

The astonishing new TR-800 system adds up to everything you've ever wished for in a one-inch tape system. Check it out for yourself. And be prepared to be amazed.

RCA Broadcast Systems
Building 2-2
Camden, NJ 08102



Can you really afford less?

